

Motorized Stage Update

Rotary Stage $\phi 39 / \phi 59$: KRW04/KRW06

Specification changes/Improvements

- ① Additional connector option
- ② Opposite hand
- ③ Improved sensor board
- ④ Electrical Specification changes
- ⑤ Dimensions/Sensor board position/size
- ⑥ Model code system

Precision specifications and Price unchanged by the update.

① Additional connector option

Current model

KRW04



KRW06



New model

KRW04 Pigtail



KRW04 Panel Mount

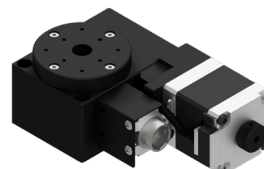

KRW06 Pigtail



KRW06 Panel Mount

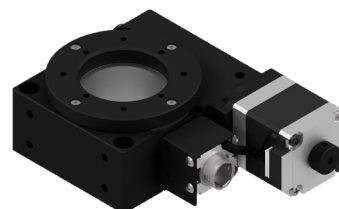

② Opposite hand

KRW06360M-LC

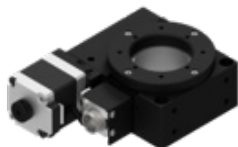

KRW06360M-RC

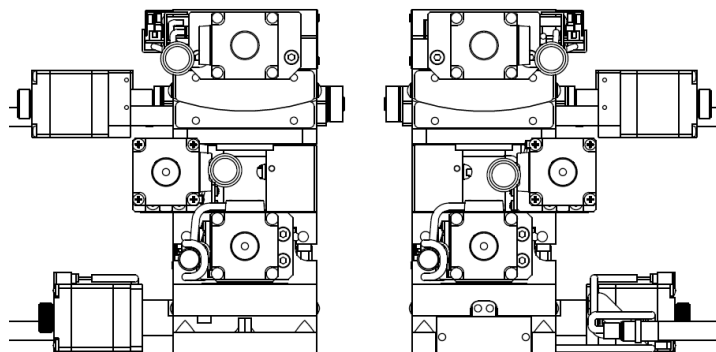
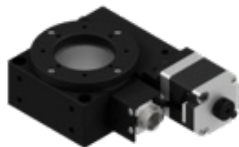

Added the opposite side specification to the rotating stage. It is possible to support close arrangement when combining and symmetrical cable routing, and improve the degree of freedom in design.

Motorized Stage Update

Rotary Stage ϕ 39/ ϕ 59 : KRW04/KRW06

⑥ Model code system

Current model

KRW 04360 -

1 2 3 4

1 Stage size

04	ϕ 39mm
06	ϕ 59mm

2 Travel distance

360	360°
-----	------

※Stage size [06] : 360C

3 Mounting

Code	Specification
Blank	Horizon
Z	Vertical

※Z is only for KRW06

4 Calbe option

Code	Specification
Blank	Cable is not included (Standard)
A	2m
B	2m One end loose
C	4m
D	4m One end loose
E	Only connector (Cable is not included)
F	Robot cable 2m
G	Robot cable 2m one end loose
H	Robot cable 4m
J	Robot cable 4m one end loose

New model

KRW 04 360M - **C** - -

1 2 3 4 5 6 7



1 Stage size

04	ϕ 39mm
06	ϕ 59mm

2 Travel distance

360	360°
-----	------

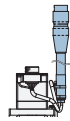
3 Connector specifications

T	Pigtail	
M	Panel Mount	

4 Sensor cover location

Code	Specification
L	L position
R	Oppsite hand

5 Motor option

Code	Specification
C	Standard

6 Cable option

Code	Specification
Blank	Cable is not included (Standard)
A	2m
B	2m One end loose
C	4m
D	4m One end loose
E	Only connector (Cable is not included)
F	Robot cable 2m
G	Robot cable 2m one end loose
H	Robot cable 4m
J	Robot cable 4m one end loose

7 Mounting

Code	Specification
Blank	Horizon
Z	Vertical

◆ Example of model code change

- KRW04360 - A → KRW04360**T** - **LC** - A
- KRW06360C - ZA → KRW06360**T** - **LC** - A - Z

Motorized Stage Update

Rotary Stage ϕ 39/ ϕ 59 : KRW04V/KRW06V

⑥ Model code system

Current model

KRW04360 V - P28

1

1 Application Motor

Code	Specification
P28	<input type="checkbox"/> 28 Stepping motor specification
S38	<input type="checkbox"/> 38 Servo motor specification
S40	<input type="checkbox"/> 40 Servo motor specification

KRW06360 V - P28

1

New model

KRW04360 **M** V - P28

1

2

3



KRW06360 **M** V - P28

1

2

3

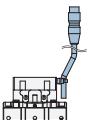
1 Connector specifications

T	Pigtail	
M	Panel Mount	

2 Sensor cover location

Code	Specification
L	L position
R	Opposite hand

3 Application Motor

Code	Specification
P28	<input type="checkbox"/> 28 Stepping motor specification
S38	<input type="checkbox"/> 38 Servo motor specification
S40	<input type="checkbox"/> 40 Servo motor specification

◆ Example of model code change

• KRW04360V - P28 → KRW04360**T**V - LP28