

Single Axis Actuator

Single Axis Actuators SX30 Motor Wrapped Type

Convenient Sensor Sets are also available. P.A-032

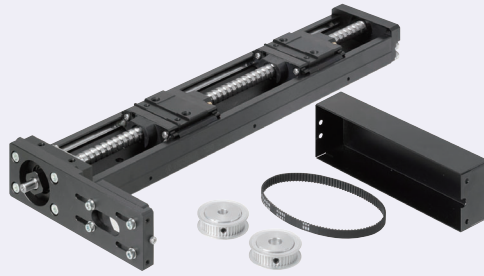

Specifications	
SX30	
Standard / Cover	
Screw Shaft Dia. (mm)	10
Lead (mm)	5, 10
Accuracy	High Grade

Accessories

- ① Motor Adapter Plates
M Steel S Low Temperature Black Chrome Plating
- ② Adapter Plate Screw 4 pcs.
M 302HQ Stainless Steel
- ③ High Torque Timing Pulley Part Number: HTPA44S2M060
- ④ High Torque Timing Belt Part Number: HTBN230S2M-60

RoHS

Part Number	Standard Grease		Lubrication Unit MX-equipped (Standard Grease)	
	High Grade Standard	High Grade with Cover	High Grade Standard	High Grade with Cover
Lead 5	SXR3005	SXR3005C	SXR3005-MX	SXR3005C-MX
Lead 10	SXR3010	SXR3010C	SXR3010-MX	SXR3010C-MX

Components	Base (Rail)	Block	Motor Bracket	Support Side Bearing with Housing	Cover	Stopper	Precision Ball Screw (Ground)
M Material	Carbon Steel	SCM Material	5052 Aluminum Alloy	5052 Aluminum Alloy	6063 Aluminum Alloy	NBR Nitrile Rubber	SCM415
S Surface Treatment	Low Temperature Black Chrome Plating	Low Temperature Black Chrome Plating	Black Baked Paint Finish	Black Anodize	Black Anodize	-	-
H Hardness	Induction Hardened HRC58~64	HRC58~62	-	-	-	-	HRC58~62

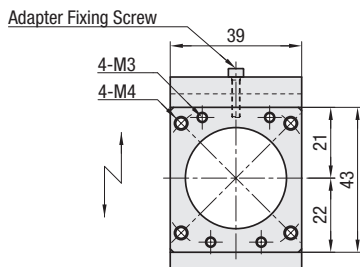
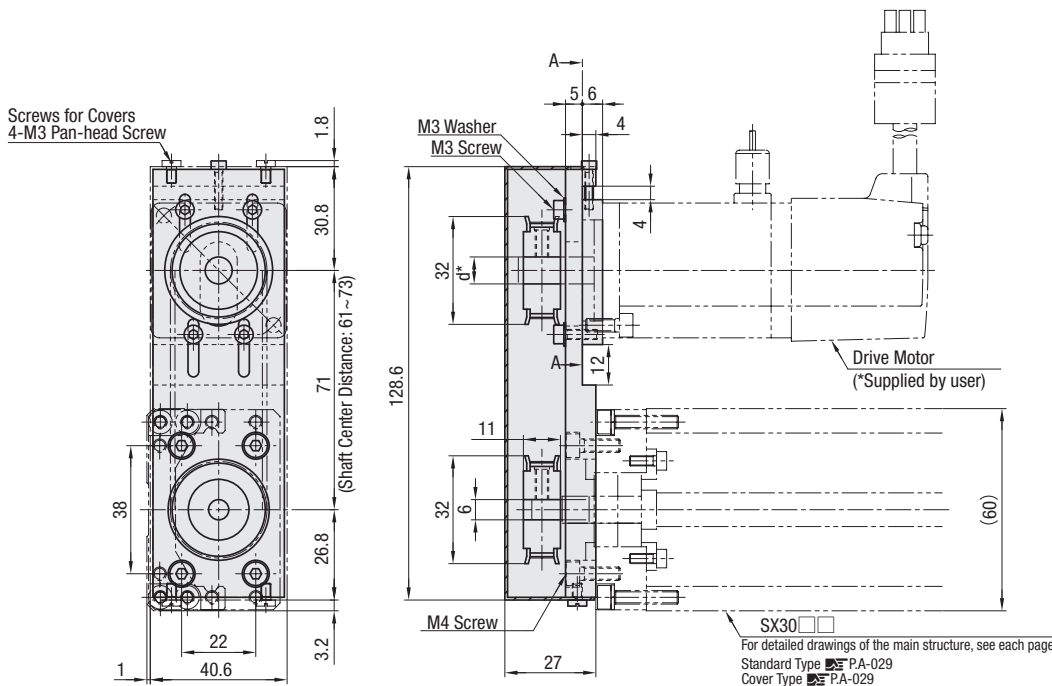

Arrow View A-A
 <Motor Adapter Plates>
 * For details of motor adapter plate dimensions, see the right-hand page.

⚠ Recommended belt tension
 When the shaft center distance is 71mm and the center of the belt is pressed with less than 1N, the deflection is 1.1mm.

SX Related Information
 Specifications PA-015~PA-018
 Selection / Life Calculation Example PA-057~PA-060



CAD 2D

New

Single Axis Actuator

Part Number	Block Qty.	Motor Adapter Plates	Base Overall Length (L)	Details of Mounting Hole Dimensions PA-029・030							
				A	P1	P2	B	Number of Pitches	Number of Holes (N)		
(High Grade Standard) SXR3005 SXR3010 (Lubrication Unit MX Standard) SXR3005-MX SXR3010-MX	Long Blocks (1 pc.)B1 (2 pcs.)B2 ⊕ For B2, L≥300 Short Blocks (1 pc.)S1 (2 pcs.)S2 *Lubrication Units MX-equipped types are available in B1/S1 only.	(Servo) RA3038 RA3040 (Stepping) RT3042 *(No Adapter Plate) N5(Pulley Inner Dia. φ5) N6(Pulley Inner Dia. φ6) N8(Pulley Inner Dia. φ8)	125	12.5	-	100	12.5	1	4		
			150	25			25				
			200								
			250				50			2	6
			300				100			3	8
			350				50			4	10
			400				100			5	12
			450				50				
			500				100				
			550				50				
600		100									

*Motor adapter plate and mounting screws are not included with No Adapter Plate Type.

Effective Stroke / Mass

Base Length (L)	* Effective Stroke						Total Mass (kg)							
	MX-unequipped			MX-equipped			SXR30□□			SXR30□□C				
	B1	B2	S1	S2	B1	S1	B1	B2	S1	S2	B1	B2	S1	S2
125	29	-	54.5	-	-	-	1.55	-	1.43	-	2.01	-	1.75	-
150	54	-	79.5	17	-	65.5	1.72	-	1.60	1.78	2.17	-	1.92	2.23
200	104	-	129.5	67	90	115.5	2.06	-	1.93	2.11	2.50	-	2.25	2.57
250	154	-	179.5	117	140	165.5	2.39	-	2.27	2.45	2.84	-	2.59	2.91
300	204	116	229.5	167	190	215.5	2.73	3.04	2.60	2.78	3.17	3.74	2.92	3.24
350	254	166	279.5	217	240	265.5	3.06	3.37	2.94	3.12	3.51	4.08	3.26	3.58
400	304	216	329.5	267	290	315.5	3.40	3.71	3.27	3.46	3.85	4.41	3.60	3.91
450	354	266	379.5	317	340	365.5	3.74	4.04	3.61	3.79	4.18	4.75	3.93	4.25
500	404	316	429.5	367	390	415.5	4.07	4.38	3.95	4.13	4.52	5.08	4.27	4.58
550	454	366	479.5	417	440	465.5	4.41	4.72	4.28	4.46	4.85	5.42	4.60	4.92
600	504	416	529.5	467	490	515.5	4.74	5.05	4.62	4.80	5.19	5.76	4.94	5.26

*Effective stroke is indicated in dimensions with a margin of 2.5 mm each from the ends.

⊕ MX-equipped types are +0.011kg.

Accuracy Standards

Accuracy Standards	L<400	L≥450
	High Grade	
Positioning (mm)	0.06	0.1
Backlash (mm)	0.02	0.02
Positioning Repeatability (mm)	±0.005	±0.005
Running Parallelism (mm)	0.025	0.035
Starting Torque (N-cm)	4	

Allowable Static Load / Moment

Block Qty.	Block Qty.	Static Load Capacity (N)	Allowable Static Moment (N-m)		
			Ma	Mb	Mc
Long Block	B1	17218	126	126	387
	B2	34436	1515	1515	774
Short Block	S1	9271	63	63	208
	S2	18542	579	579	417

⊕ For allowable static moment, see PA-015

Maximum Velocity

Max. Velocity (mm/s)	L125~L450	L500	L550	L600
SXR3005□□	410	370	300	250
SXR3010□□	830	740	600	500

⊕ The maximum velocity is reference values derived from ball screw critical speeds and DN values but not guarantee data considering the motor's conditions.

Servo Motor Application Table

Part Number	Flange Size	Manufacturer	Product Number	Wattage	Applicable Motor Shaft Dia.
RA3038	□38	Panasonic	MSMD5A	50W	φ8
			MSME5A	100W	
			MSMD01*		
MSME01*					
RA3040	□40	YASKAWA Electric Corporation	SGMJV-A5A	50W	
			SGM7A-01A	100W	
		Mitsubishi Electric Corporation	HG-MR053	50W	
			HG-MR13	100W	
		OMRON Corporation	R88M-K10030	50W	
			SV-M005	50W	
SV-M010	100W				

Stepping Motor Application Table

Part Number	Flange Size	Manufacturer	Product Number	Type	Applicable Motor Shaft Dia.
RT3042	□42	Oriental Motor	PK24*	2-phase	φ6
			RKS54*	5-phase	
			ARM46	αSTEP	

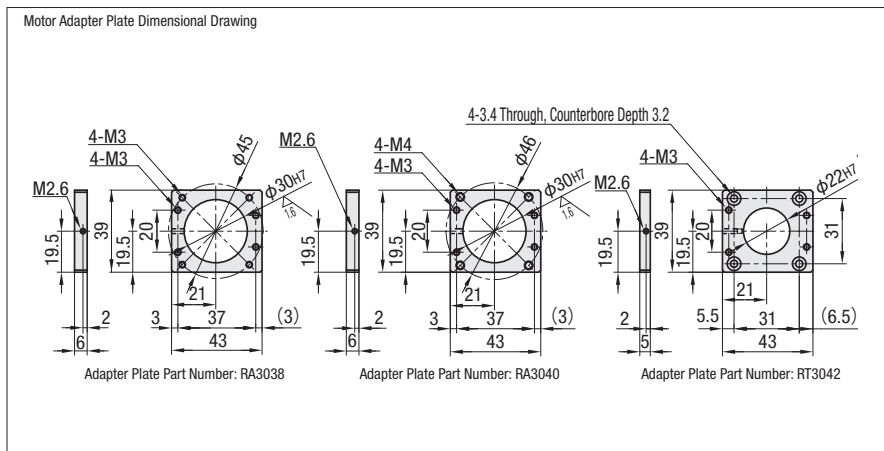

Part Number	-	Block Qty.	-	Motor Adapter Plates	-	Base Length (L)
SXR3010C	-	B1	-	RA3040	-	600
SXR3005-MX	-	B1	-	RA3040	-	600
Part Number	-	Block Qty.	-	Motor Adapter Plates	-	Base Length (L)
SXR3010C	-	B1	-	RA3040	-	600

Alteration	Code	Spec.
No Belt / No Pulley	NBP	Excluded from the set.

⊕ Sensor Set PA-032

Part Number	Block Qty.	Screw Shaft Dia.	Lead
SXR30□□-B1/S1-□	1	10	5
SXR30□□-B2/S2-□	2		
SXR30□□-C-B1/S1-□	1		10
SXR30□□-C-B2/S2-□	2		

Single Axis Actuators SX45 Motor Wrapped Type

Convenient Sensor Sets are also available. P.A-036

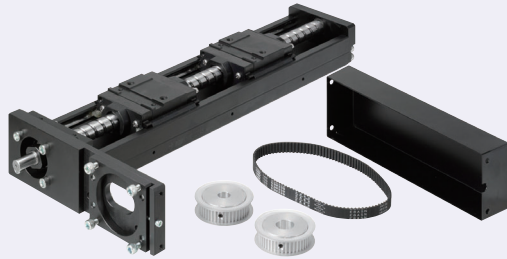

Specifications	
SX45	
Standard / Cover	
Screw Shaft Dia.(mm)	15
Lead(mm)	10, 20
Accuracy	High Grade

- A** Accessories
- ① Motor Adapter Plates
 - M** Steel **S** Low Temperature Black Chrome Plating
 - ② Adapter Plate Screw 4 pcs.
 - M** 302HQ Stainless Steel
 - ③ High Torque Timing Pulley Part Number: HTPA44S3M100
 - ④ High Torque Timing Belt Part Number: HTBN339S3M-100

RoHS

Part Number	Standard Grease		Lubrication Unit MX-equipped (Standard Grease)	
	High Grade Standard	High Grade with Cover	High Grade Standard	High Grade with Cover
Lead 10	SXR4510	SXR4510C	SXR4510-MX	SXR4510C-MX
Lead 20	SXR4520	SXR4520C	SXR4520-MX	SXR4520C-MX

Components	Base (Rail)	Block	Motor Bracket	Support Side Bearing with Housing	Cover	Stopper	Precision Ball Screw (Ground)
M Material	Carbon Steel	SCM Material	5052 Aluminum Alloy	5052 Aluminum Alloy	6063 Aluminum Alloy	NBR Nitrile Rubber	SCM415 Alloy Steel (JIS)
S Surface Treatment	Low Temperature Black Chrome Plating	Low Temperature Black Chrome Plating	Black Baked Paint Finish	Black Anodize	Black Anodize	-	-
H Hardness	Induction Hardened HRC58 ~ 64	HRC58 ~ 62	-	-	-	-	HRC58 ~ 62

Screws for Covers
4-M4 Pan-head Screw

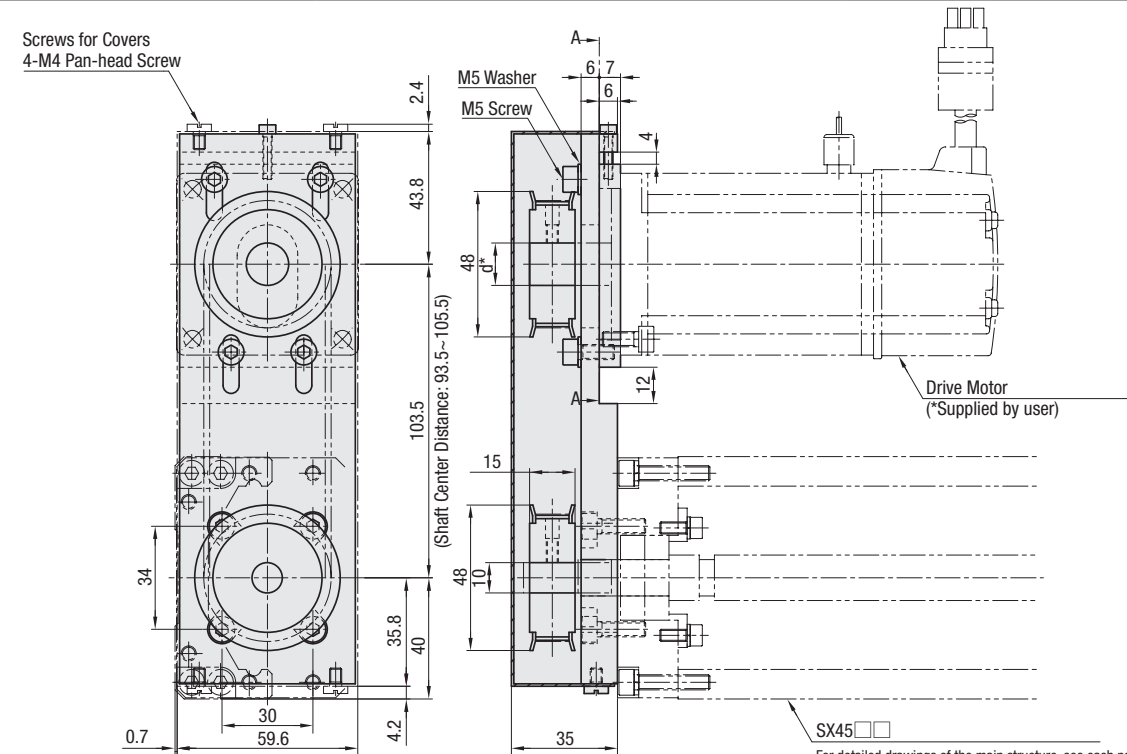

For detailed drawings of the main structure, see each page.
Standard Type P.A-033
Cover Type P.A-033

*d is Pulley Inner Dia.
φ14 for Servo Motor Type and φ8 for Stepping Motor Type. Selectable for No Adapter Plate Type.

Adapter Fixing Screw

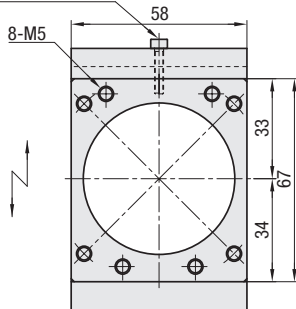

Arrow View A-A

<Motor Adapter Plates>
*For details of motor adapter plate dimensions, see the right-hand page.

⚡ Recommended belt tension
When the shaft center distance is 103.5mm and the center of the belt is pressed with less than 3N, the deflection is 1.7mm.

SX Related Information
 Specifications P.A-015~P.A-018
 Selection / Life Calculation Example P.A-057~P.A-060



CAD 2D

New

Single Axis Actuator

Part Number	Block Qty.	Motor Adapter Plates	Base Overall Length (L)	Details of Mounting Hole Dimensions P.A-033 • 034					
				A	P1	P2	B	Number of Pitches	Number of Holes (N)
(High Grade Standard) SXR4510 SXR4520 (Lubrication Unit MX Standard) SXR4510-MX SXR4520-MX	Long Blocks (1 pc.)B1 (2 pcs.)B2 Short Blocks (1 pc.)S1 (2 pcs.)S2 *Lubrication Units MX-equipped types are available in B1/S1 only.	(Servo) RA4560 (Stepping) RT4560 *(No Adapter Plate) N8 (Pulley Inner Dia. φ8) N10 (Pulley Inner Dia. φ10) N14 (Pulley Inner Dia. φ14)	340	70	100	100	70	2	6
			390			50		3	8
			440			100		4	10
			490			50		5	12
			540			100			
			590			50			

*Motor adapter plate and mounting screws are not included with No Adapter Plate Type.

Effective Stroke / Mass

Base Length (L)	Effective Stroke						Total Mass (kg)							
	MX-unequipped				MX-equipped		SXR45□□				SXR45□□C			
	B1	B2	S1	S2	B1	S1	B1	B2	S1	S2	B1	B2	S1	S2
340	210.4	88.8	247.9	163.8	194.4	231.9	6.42	7.34	6.02	6.56	7.24	8.74	6.59	7.43
390	260.4	138.8	297.9	213.8	244.4	281.9	7.02	7.94	6.63	7.16	7.88	9.38	7.22	8.06
440	310.4	188.8	347.9	263.8	294.4	331.9	7.62	8.55	7.23	7.76	8.51	10.01	7.85	8.69
490	360.4	238.8	397.9	313.8	344.4	381.9	8.22	9.15	7.83	8.36	9.14	10.64	8.49	9.33
540	410.4	288.8	447.9	363.8	394.4	431.9	8.83	9.75	8.43	8.96	9.78	11.28	9.12	9.96
590	460.4	338.8	497.9	413.8	444.4	481.9	9.43	10.35	9.04	9.57	10.41	11.91	9.75	10.59

*Effective stroke is indicated in dimensions with a margin of 2.5 mm each from the ends.

MX-equipped types are +0.024kg.

Accuracy Standards

Accuracy Standards	High Grade
Positioning (mm)	0.1
Backlash (mm)	0.02
Positioning Repeatability (mm)	±0.005
Running Parallelism (mm)	0.035
Starting Torque (N-cm)	10

Allowable Static Load / Moment

Block Qty.	Block Qty.	Static Load Capacity (N)	Allowable Static Moment (N-m)		
			Ma	Mb	Mc
Long Block	B1	32441	291	291	972
	B2	64882	3945	3945	1944
Short Block	S1	17175	145	145	515
	S2	34350	1444	1444	1029

For allowable static moment, see P.A-015

Maximum Velocity

	Max. Velocity (mm/s)
SXR4510□	550
SXR4520□	1110

The maximum velocity is reference values derived from ball screw critical speeds and DN values but not guarantee data considering the motor's conditions.

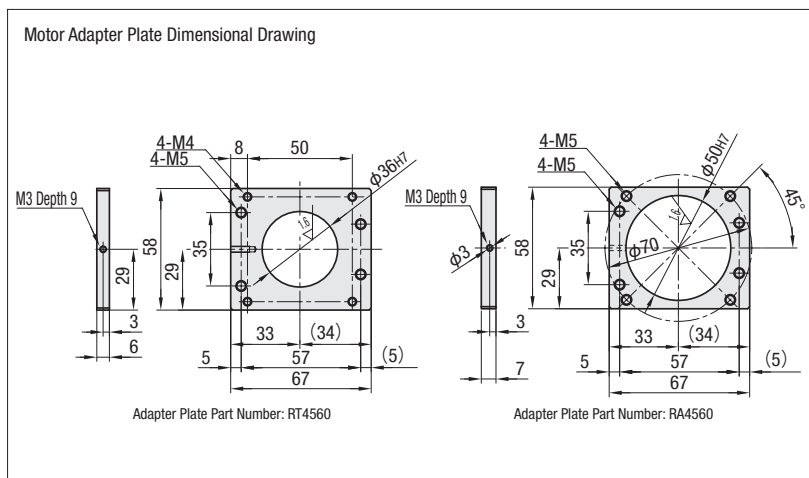

Servo Motor Application Table

Part Number	Flange Size	Manufacturer	Product Number	Wattage	Applicable Motor Shaft Dia.
RA4560	□60	YASKAWA Electric Corporation	SGMJV-02	200W	φ14
			SGMJV-04A	400W	
		Mitsubishi Electric Corporation	HG-MR23	200W	
			HG-KR23	200W	
		Keyence Corporation	HG-MR43	400W	
			SV-M040	400W	

Stepping Motor Application Table

Part Number	Flange Size	Manufacturer	Product Number	Type	Applicable Motor Shaft Dia.
RT4560	□60	Oriental Motor	RKS56* ARM66	5-phase αSTEP	φ10



Part Number	-	Block Qty.	-	Motor Adapter Plates	-	Base Length (L)	-
SXR4510	-	B1	-	RA4560	-	540	-
SXR4510C-MX	-	B1	-	RA4560	-	540	-
Part Number	-	Block Qty.	-	Motor Adapter Plates	-	Base Length (L)	-
SXR4510	-	B1	-	RA4560	-	540	-
							- NBP

Alteration	Code	Spec.
No Belt / No Pulley	NBP	Excluded from the set.

Sensor Set P.A-036

Part Number	Block Qty.	Screw Shaft Dia.	Lead
SXR45□□-B1/S1-□	1	15	10
SXR45□□-B2/S2-□	2		
SXR45□□C-B1/S1-□	1		20
SXR45□□C-B2/S2-□	2		