

Linear Ball Guide Stage Guidance/Line-up

[Features]

- Thin structure stages which integrate the guide and main body.
- The combination of the stainless mainbody and gothic arc groove for a guide allows high rigidity and high accuracy. ※BXT series made by steel.
- Its wide specification line up helps customers improve productivity and quality.

Mechanism

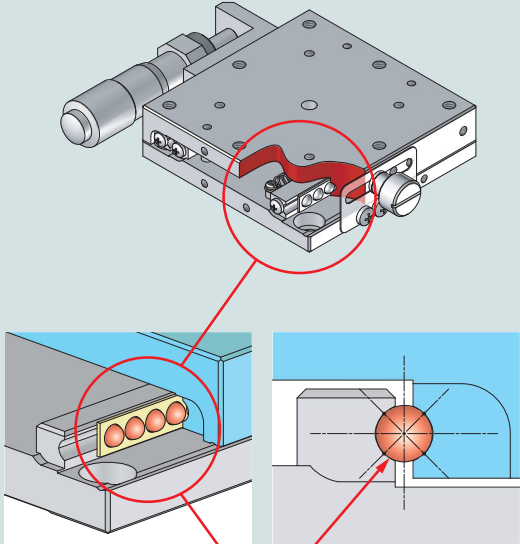

Gothic arc groove
(4points contact rolling mechanism)

Feature

- Thin type Main body thickness :16mm
- High rigidity Load capacity :20kgf
- High precision Straightness :1μm

*Specification example in case of 60x60mm

Low price Low price linear ball guide BXT series ▶ P.2-015~

Series	Stage table size (mm)	Travel distance per rotation (mm)	Load capacity (kgf [N])	Main material
BXT series (Electroless nickel plating)	□40	0.5	10 [98]	Steel
	□60		20 [196]	
BSS series (Electroless nickel plating)	□25	0.25~0.5	4 [39.2]	Stainless
	□40		10 [98]	
	□50		15 [147]	
	□60	0.25~1.0	20 [196]	
	□70		23 [225.4]	
	□80	0.5~1.0	27 [264.6]	
	□100		35 [343]	
BSB series (Low temperature black chrome plating)	□25	0.25~0.5	4 [39.2]	Stainless
	□40		10 [98]	
	□60	0.25~1.0	20 [196]	
	□80		27 [264.6]	
BSL series (Long stroke)	40×80	0.5~1.0	15 [147]	Stainless
	60×120		20 [196]	

* Amount shows for single axis

XY thin type BSS23 series

Reduce 31% of thickness by integrated XY

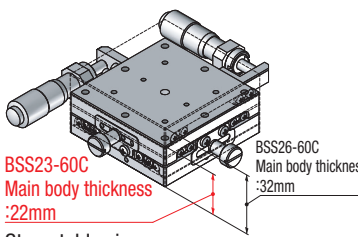

BSS23-60C Main body thickness :22mm
 BSS26-60C Main body thickness :32mm

Stage table size 40×40~100×100mm ▶ P.2-039~

Clamp on a operator's end

Control operation from the one-way direction



XY-axis ▶ P.2-035~

Multi mounting positioning

Can be mounted a variety of direction such as vertical, tilt and horizontal.



▶ P.2-037~

XY-axis Linear Ball Guide BYT Series □40□60: BYT04013/BYT06013

RoHS



BYT04013-CL



BYT06013-CL

1 Model
BYT04013-CL
 Option code
 1 2 3

1 Stage table size

04	40mm
06	60mm

2 Travel distance

013	13mm
-----	------

3 Operating position

L	L opposite hand
R	Opposite hand

Linear Ball

Cross Roller

Dovetail

□25

□30

□40

□50

□60

□70

□80

□100

□120

Other

SPEC		
Model	BYT04013	BYT06013
Stage table size	40×40mm	60×60mm
Operation position	Side	Side
Travel distance	±6.5mm	±6.5mm
Travel distance per rotation of feed screw	0.5mm	0.5mm
Minimum reading of micrometer	10μm	10μm
Travel guide	Linear ball guide	Linear ball guide
Load capacity	9.8kgf [96N]	19.6kgf [192.1N]
Travel accuracy	Straightness (Single axis accuracy)	10μm
	Pitching (Single axis accuracy)	30"
	Yawing (Single axis accuracy)	25"
Moment rigidity	Pitch	0.59"/N · cm
	Yaw	0.70"/N · cm
	Roll	0.59"/N · cm
Parallelism	60μm	60μm
Weight	0.48kg	0.88kg
Main material—Surface finishing	Steel—Electroless nickel plating	Steel—Electroless nickel plating
Provided screws (Hex socket screws)	4 of M3—8	4 of M4—8

Dimensional outline drawings

BYT04013-CL

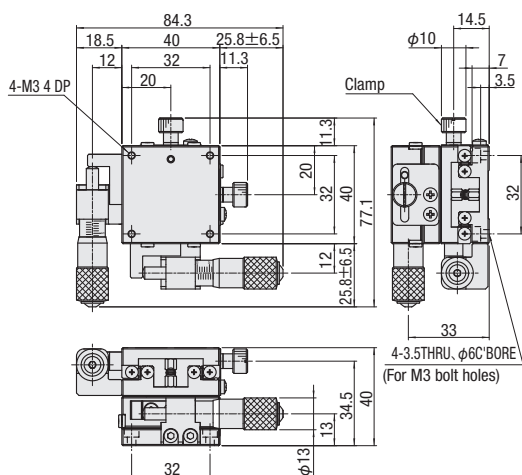

BYT04013-CR

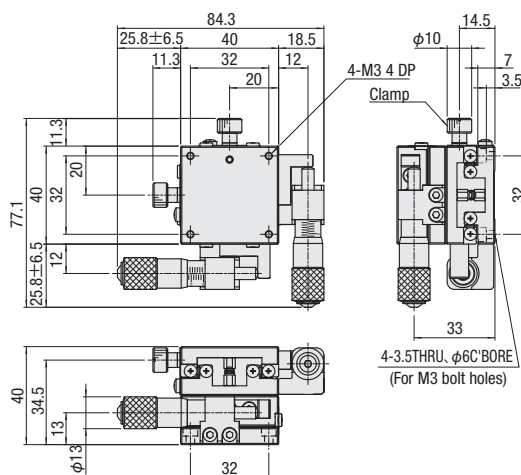

BYT06013-CL

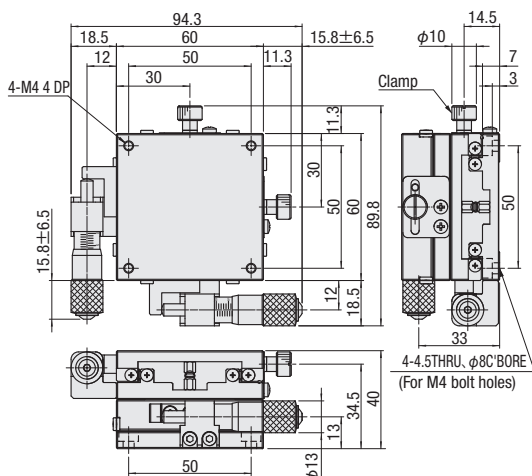

BYT06013-CR

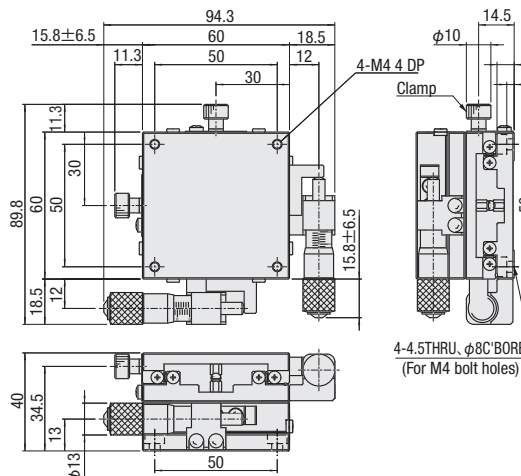

Manual linear stage

X

XY

Z

Horizontal Z

XZ

Horizontal XZ

XYZ

Horizontal XYZ

Goniometer

Rotary

Unit

Accessories

Linear Ball

Cross Roller

Dovetail

25

30

40

50

60

70

80

100

120

Other

2

044

Z-axis Linear Ball Guide BZT Series □40□60: BZT04013/BZT06013

RoHS



BZT04013-UL

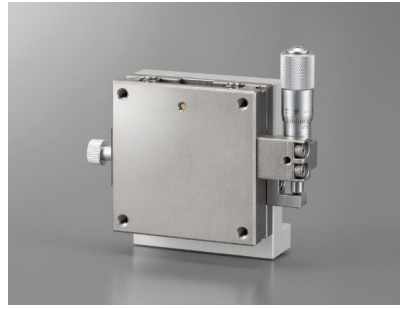

BZT06013-UL

Manual linear stage

X

XY

Z

Horizontal Z

XZ

Horizontal XZ

XYZ

Horizontal XYZ

Goniometer

Rotary

Unit

Accessories

Linear Ball

Cross Roller

Dovetail

□25

□30

□40

□50

□60

□70

□80

□100

□120

Other

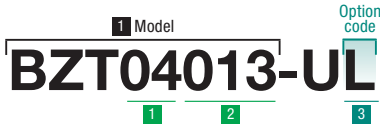

1 Stage table size

04	40mm
06	60mm

2 Travel distance

013	13mm
-----	------

3 Operating position

L	L opposite hand
R	Opposite hand

SPEC		
Model	BZT04013	BZT06013
Stage table size	40×40mm	60×60mm
Operation position	Side	Side
Travel distance	±6.5mm	±6.5mm
Travel distance per rotation of feed screw	0.5mm	0.5mm
Minimum reading of micrometer	10μm	10μm
Travel guide	Linear ball guide	Linear ball guide
Load capacity	2.0kgf [19.6N]	2.0kgf [19.6N]
Travel accuracy	Straightness	10μm
	Pitching	30"
	Yawing	25"
Moment rigidity	Pitch	0.38"/N · cm
	Yaw	0.35"/N · cm
	Roll	0.21"/N · cm
Parallelism	—	—
Weight	0.42kg	0.82kg
Main material—Surface finishing	Steel—Electroless nickel plating	Steel—Electroless nickel plating
Provided screws (Hex socket screws)	2 of M3—16	2 of M4—16

Dimensional outline drawings

BZT04013-UL

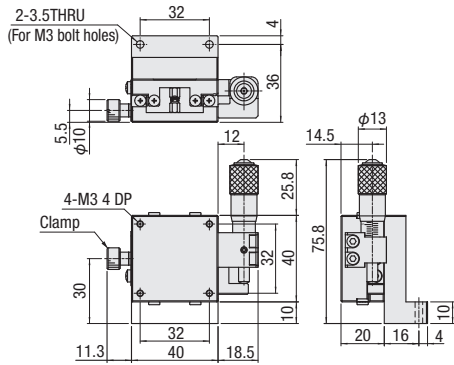

BZT04013-UR

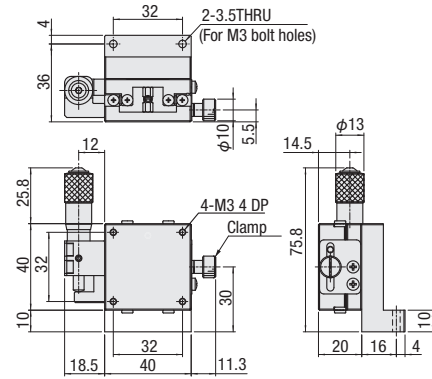

BZT06013-UL

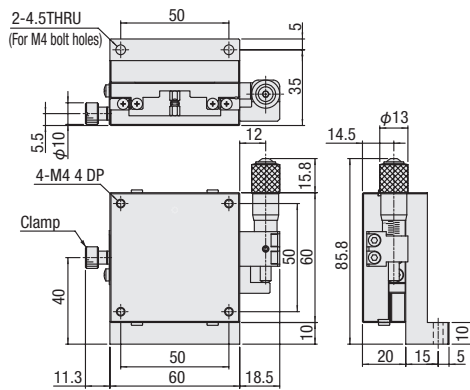

BZT06013-UR

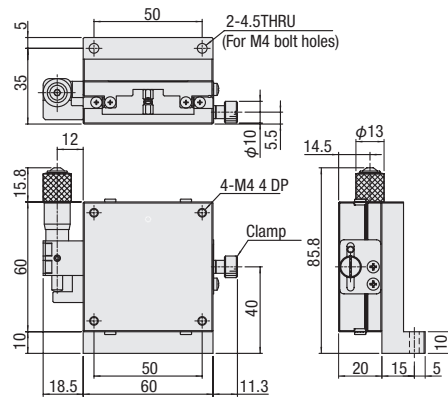

Manual linear stage

X

XY

Z

Horizontal Z

XZ

Horizontal XZ

XYZ

Horizontal XYZ

Goniometer

Rotary

Unit

Accessories

Linear Ball

Cross Roller

Dovetail

25

30

40

50

60

70

80

100

120

Other

2

054