

# Motorized Stage

## Horizontal Z-axis Stage: KHE04006-C/KHE06008-C(Linear ball guide)

Motorized Stage

KHE04006



KHE06008

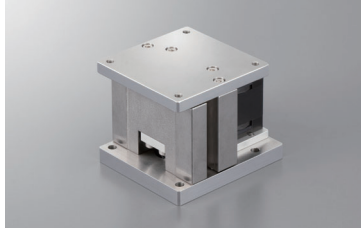

RoHS

\* The photo shows an image.  
The holes and the shape may differ in certain respects from the actual product.

X

XY

Z

Horizontal Z

XYZ

Goniometer

Rotary

Unit

Controller

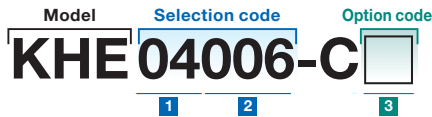

▶ Cable P.1-207~  
▶ Electrical specification P.1-115~

### 1 Table size

04	<input type="checkbox"/> 40mm
06	<input type="checkbox"/> 60mm

### 2 Travel length

006	6mm
008	8mm

### 3 Cable option

Code	Specification	Cable type
F	Robot cable 2m	D214-2-2R
G	Robot cable 2m one end loose	D214-2-2RK
H	Robot cable 4m	D214-2-4R
J	Robot cable 4m one end loose	D214-2-4RK
Blank	Cable is not included (Standard)	—

\* If you choose the option specification, please add the difference to standard price.

Electrical specification ▶ P.1-115~

\* See page ▶ P.1-207, 209~ for more cable details.

\* Please select "Code F or H" when connect with stepping motor controller(DS102/112).

Linear Ball

CAVE-X  
Linear ball

Cross Roller

Slide Guide

40

50

60

70

80

100

120

Other

### SPEC

Model	KHE04006-C	KHE06008-C
Travel length	6mm	8mm
Table size	40×40mm	60×60mm
Feed screw (Ball screw)	φ6 lead 1	φ8 lead 1
Guide	Linear ball guide	
Main materials-Finishing	Steel—Opposite side of the end face finishing	
Weight	0.5kg	0.92kg
Resolution (Pulse)	2μm (Full)/1μm (Half)	
MAX speed	10mm/sec	
Positioning accuracy	—	
Repeatability positioning accuracy	Within ±5μm	
Load capacity	3kgf [29N]	4kgf [39N]
Lost motion	Within 5μm	
Parallelism	Within 80μm	
Limit sensor	Installed	
Origin sensor	Installed	
Provided screw (Hexagon-headed bolt)	3 of M3—16	4 of M4—14

Dimensional outline drawings

KHE04006-C

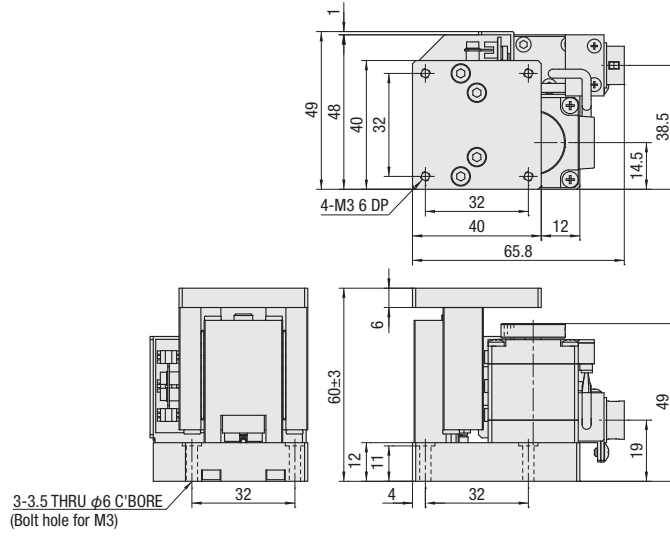

KHE06008-C

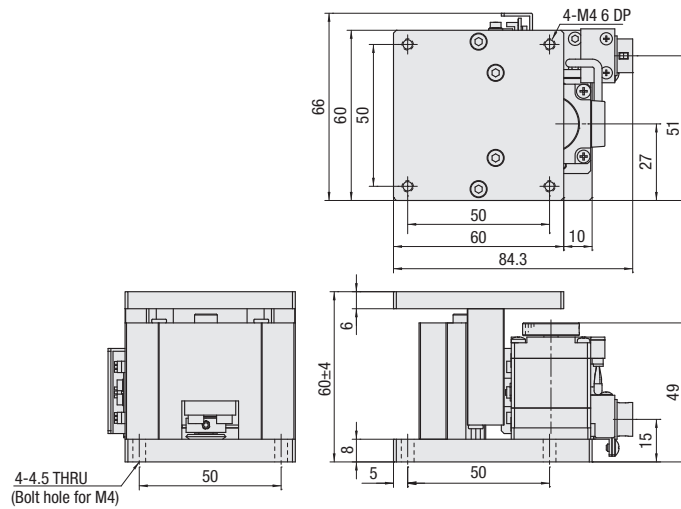

Motorized Stage

X

XY

Z

Horizontal Z

XYZ

Goniometer

Rotary

Unit

Controller

Linear Ball

CAVE-X  
Linear ball

Cross Roller

Slide Guide

40

50

60

70

80

100

120

Other

# Motorized Stage

## Electrical Specification: KHE04006-C/KHE06008-C

Motorized Stage

### Electrical specification

Models		KHE04006-C	KHE06008-C
Motor (*1)	Type	5 phase stepping motor 0.75A/Phase	
	Maker	Oriental Motor Co., Ltd.	
	Model (*2)	PK523HPB-C17	
	Step angle	0.72°	
Connector	Model	HR10A-10R-12PC (71) (Hirose Electric Co., Ltd.)	
	Receiving connector	HR10A-10P-12S (73) (Hirose Electric Co., Ltd.)	
Sensor	Limit sensor	Installed	
	Origin sensor	Installed	
	Model	Photo microsensor EE-SX4320 (Omron Co., Ltd.)	
	Power voltage	DC5~24V ±10%	
	Consumption current	Total 60mA or less	
	Control output	NPN open collector output DC5~24V 8mA or less Residual voltage 0.3V or less when the load current is 2mA	
	Limit output logic	On detection (light shield condition): Output transistor OFF (Non-continuity)	
	Origin output logic	Detection (Light): Output transistor ON (Continuity)	

\*1 See page P.1-177~ for details of single motor specification

\*2 Model is our own management model.

### Pin allocation

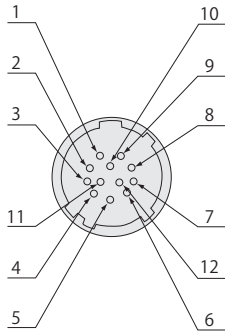

### Connection diagram

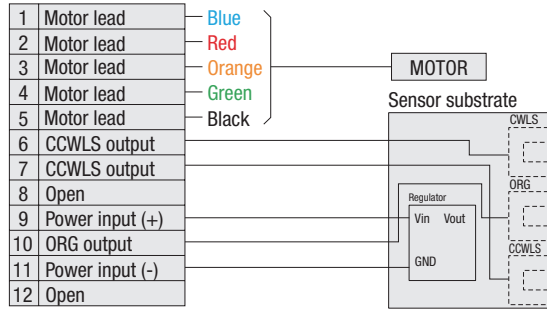

### Timing chart

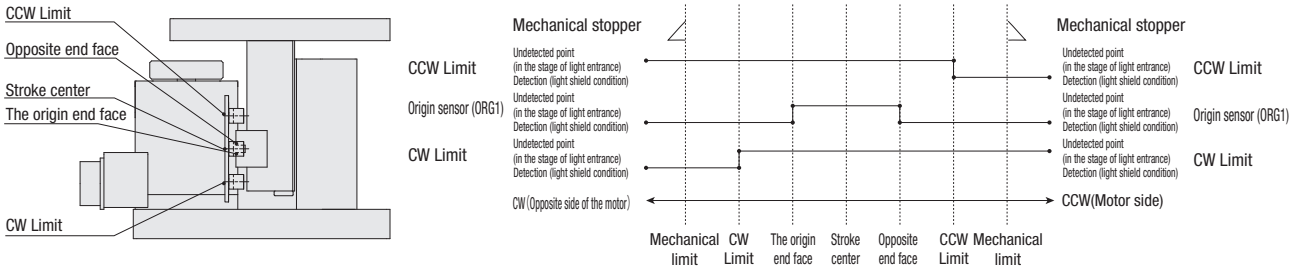

Unit [mm]	Reference coordinate	Direction of CW ←					→ Direction of CCW	
		Mechanical limit	CW Limit	Origin	Stroke center	Opposite end face	CCW Limit	Mechanical limit
<b>KHE04006-C</b>	Return to origin	3	2.2	0	1	2	4.2	5
	Stroke center	4	3.2	1	0	1	3.2	4
<b>KHE06008-C</b>	Return to origin	4	3.2	0	1	2	5.2	6
	Stroke center	5	4.2	1	0	1	4.2	5

\* Return to origin means that is performed return to origin type 4 using DS102/DS112 series.

\* The coordinate value should be on the design. Dimension error may occur about plus or minus 0.5 mm.

Note: The timing chart shows only timing of sensor, it is not for output signal logic.

Refer to ON/OFF display of output transistor that shows on electrical specifications-sensor-output logic for output signal logic.

Linear Ball

CAVE-X Linear ball

Cross Roller

Slide Guide

40

50

60

70

80

100

120

Other

**KHE series recommendation return to origin method**

Suruga's motorized stages are different from the specification depending on the models. Therefore return to origin method other than recommendation may not be work correctly. Set to the way of recommendation return origin when using our controller.

**[Type3]** Detect in the direction of CCW and perform detected process for CCW edge (a point) of ORG signal.

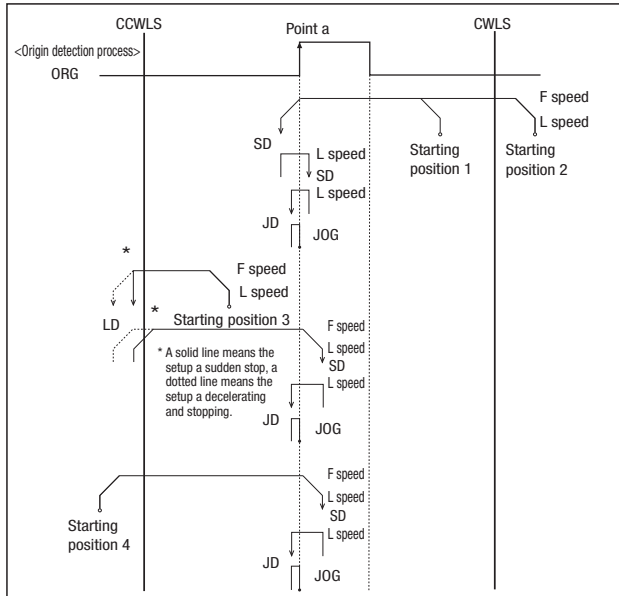

**[Type4]** Detect in the direction of CW and perform detected process for CW edge of ORG signal.

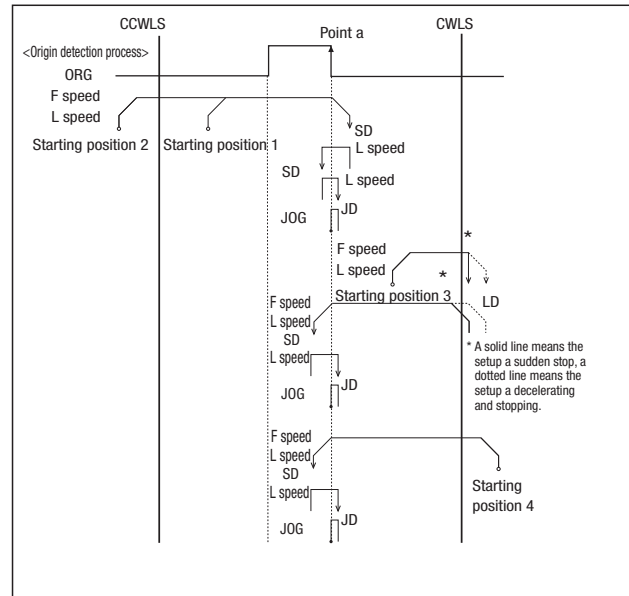

**[Type9]** After finished Type3, perform detected process for CCW edge of TIMING signal.

**[Type10]** After finished Type4, perform detected process for CW edge of TIMING signal.

Return to origin sequence P.1-201~

**Adaptive driver**

■ Driver P.1-205~

DC24 type input

Model	CRD5107P	SD5107P3-A22
Divisions	1~1/250 (16 steps)	Full/Half

AC100V input

Model	RKD507-A
Divisions	1~1/250 (16 steps)

**Adaptive stepping motor controller**

■ Controller P.1-197~

Input power	General-purpose input/output port	Driver type (Divisions)	
		Normal (Full/Half)	Micro step (1~1/250 [16 steps])
AC100-240V	Without	DS102NR	DS102MS
	With	DS102NR-IO	DS102MS-IO
DC24V	Without	DS112NR	DS112MS
	With	DS112NR-IO	DS112MS-IO



Motorized Stage

X

XY

Z

Horizontal Z

XYZ

Goniometer

Rotary

Unit

Controller

Linear Ball

CAVE-X Linear ball

Cross Roller

Slide Guide

□40

□50

□60

□70

□80

□100

□120

Other

1

116

# Motorized Stage

## Horizontal Z-axis Cross Roller Guide: KHC06004F/KHC07004F/KS332

Motorized Stage

KHC06004F

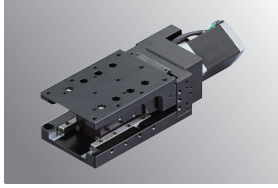

KHC07004F

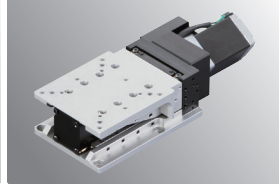

KS332-8NC

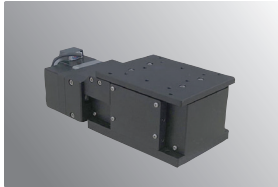

KS332-12C

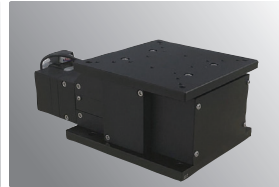

※ Can be used for KHC  
 See page P.009

■ KHE series/Low-price motorized horizontal Z stage

▶ P.1-113~

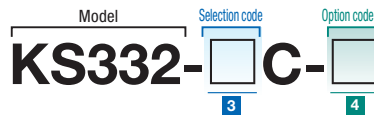
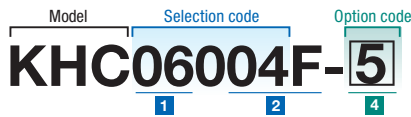
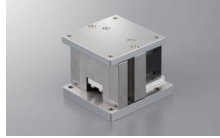

▶ Cable P.1-207~  
 ▶ Electrical specification P.1-119~

**1 Table size**

06	60mm
07	70mm

**2 Travel**

04F	4mm
-----	-----

**3 Travel**

8N	8mm
12	12mm

**4 Cable option**

Code	Specification	Cable type
Blank	2m	D214-2-2E
1	2m One end loose	D214-2-2EK
2	4m	D214-2-4E
3	4m One end loose	D214-2-4EK
4	Only connector (Cable is not included)	—
5	Cable is not included (Standard)	—
6	Robot cable 2m	D214-2-2R
7	Robot cable 4m	D214-2-4R
8	Robot cable 4m one end loose	D214-2-4RK
9	Robot cable 2m one end loose	D214-2-2RK

\* One end loose position to only stage opposite side.  
 \* If you choose the option specification, please add the difference to standard price.  
 \* See page ▶ P.1-207, 209~ for more cable details.  
 \* Please select "blank, 2, 6 and 7" when connect with stepping motor controller(DS102/112).

SPEC				
Model	KHC06004F-5	KHC07004F-5	KS332-8NC-5	KS332-12C-5
Mechanical specification				
Travel length	4mm			
Table size	60×60mm	70×70mm	80×100mm	120×120mm
Feed screw	Ball screwφ8 lead 1		Ball screwφ6 lead 1	Ball screwφ8 lead 1
Guide	Wedge type Crossed roller guide			
Main materials-Finishing	Aluminum-Black almite finishing	Aluminum-White almite finish	Aluminum-Black almite finishing	
Weight	1.14kg	1.18kg	2.0kg	3.6kg
Accuracy specification				
Resolution (Pulse)	0.25μm (Full)/0.125μm (Half)		≒0.73μm (Full)/0.365μm (Half)	
MAX speed	2.5mm/sec		≒3.7mm/sec	
Uni-directional positioning accuracy	Within 7μm		-	
Repeatability positioning accuracy	Within ±0.5μm			
Load capacity	7kgf [68.6N]		20kgf [196N]	
Moment stiffness	Pitch 0.2/yaw 0.04/roll 0.14 [°/N · cm]		Pitch 0.24/yaw 0.12/roll 0.03 [°/N · cm]	Pitch 0.20/yaw 0.11/roll 0.01 [°/N · cm]
Lost motion	Within 1μm			
Parallelism	Within 50μm			
Sensor				
Limit sensor	Installed			
Origin sensor	Installed			
Slit origin sensor	-			
Provided screw (Hexagon-headed bolt)	4 of M4-12	4 of M4-6	4 of M4-16	4 of M6-16

X

XY

Z

Horizontal Z

XYZ

Goniometer

Rotary

Unit

Controller

Linear Ball

CAVE-X Linear ball

Cross Roller

Slide Guide

40

50

60

70

80

100

120

Other

**Dimensional outline drawings**

**KHC06004F**

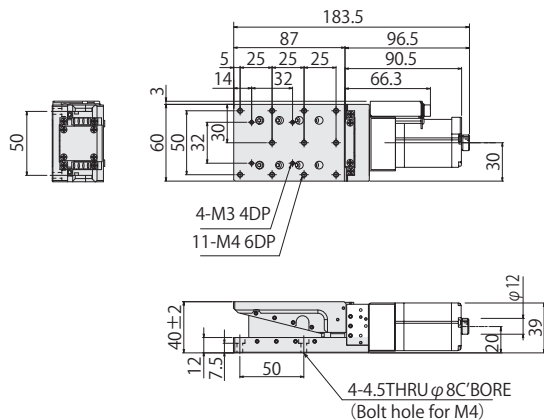

**KHC07004F**

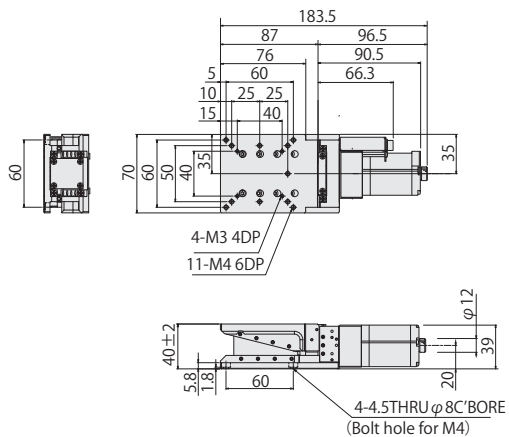

**KS332-8NC**

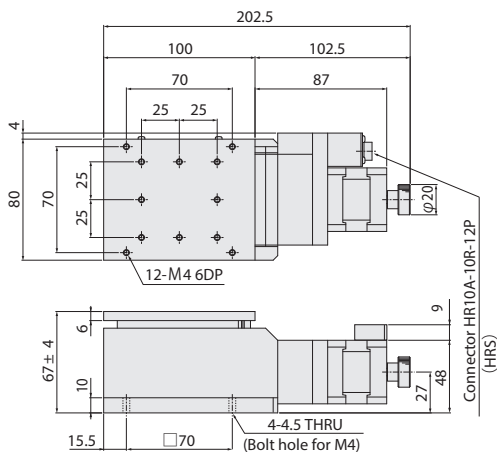

**KS332-12C**

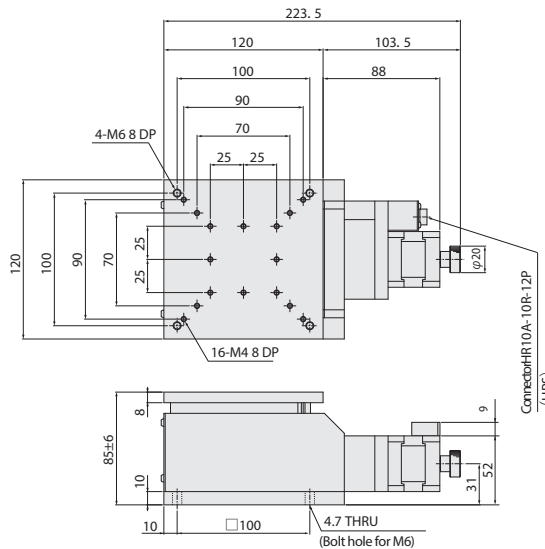

Motorized Stage

X

XY

Z

Horizontal Z

XYZ

Goniometer

Rotary

Unit

Controller

Linear Ball

CAVE-X Linear ball

Cross Roller

Slide Guide

40

50

60

70

80

100

120

Other

1

118

# Motorized Stage

## Electrical Specification: KHC06004F/KHC07004F/KS332-8NC/KS332-12C

Motorized Stage

### Electrical specification

Models	KHC06004F	KHC07004F	KS332-8NC	KS332-12C	
Motor (*1)	Type	5 phase stepping motor 0.75A/Phase (Oriental Motor Co., Ltd.)			
	Model	PK525HPB-C1 (□28mm)		PK544PB-C18	
	Step angle	0.72°		0.72°	
Connector	Model(*2)	HR10A-10R-12P (73) (Hirose Electric Co., Ltd.)			
	applicable connector on acceptance side	HR10A-10P-12S (73) (Hirose Electric Co., Ltd.)			
Sensor	Limit sensor	Installed			
	Origin sensor (ORG1)	Installed			
	Slit origin sensor (ORG2)	—			
	Model	Micro photosensor EE-SX4320(Omron Co., Ltd.)	Switches AV4044 (Panasonic) 0.1A 30V DC Photo microsensor EE-SX671 (Omron Co., Ltd.)		
	Power voltage	DC5~24V ±10%			
	Consumption current	Total 60mA or less		Total 35mA or less	
	Control output	NPN open collector output DC5~24V 8mA or less Residual voltage 0.3V or less when the load current is 2mA		NPN open collector output DC5~24V100mA or less Residual voltage 0.8V or less when the load current is 100mA Residual voltage 0.4V or less when the load current is 40mA	
Output logic(*)	On detection (light shield condition) : Output transistor OFF (Non-continuity)		On detection (light shield condition): Output transistor OFF (Non-continuity)		

\*1 See page P.1-213~ for details of single motor specification

\*2 Model is our own management model.

### Pin allocation

### Connection diagram

### Pin allocation

### Connection diagram

#### KHC06004F/KH07004F

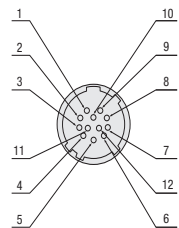

#### KHC06004F/KHC07004F

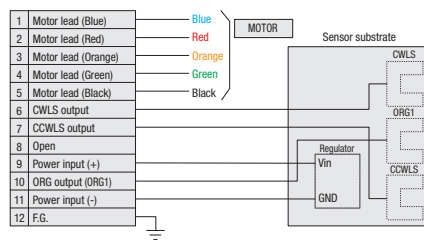

#### KS332-8NC/KS332-12C

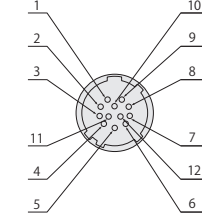

#### KS332-8NC/KS332-12C

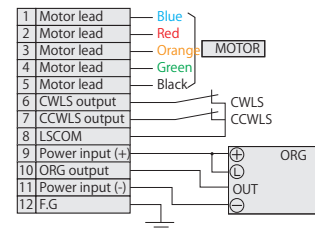

Linear Ball

CAVE-X  
Linear ball

Cross Roller

Slide Guide

□40

□50

□60

□70

□80

□100

□120

Other

Timing chart

KHC06004F/KHC07004F

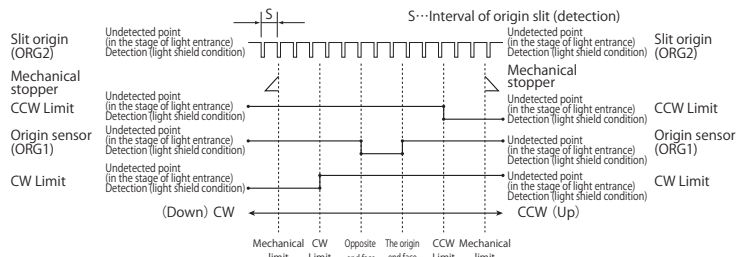
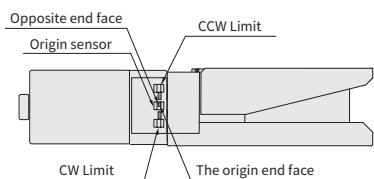

Unit [mm]	Reference coordinate	Mechanical limit	CW Limit	Opposite end face	The origin end face stroke center	CCW Limit	Mechanical limit
KHC06004F	Return to origin	2.5	2.2	1.5	0	2.2	2.5
KHC07004F	Return to origin	2.5	2.2	1.5	0	2.2	2.5

\*Return to origin means that is performed return to origin type 3 using DS102/DS112/D200 controller.  
 \* The coordinate value should be on the design. Dimension error may occur about plus or minus 0.5 mm.

KS332-8NC/KS332-12C

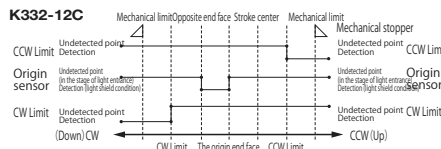
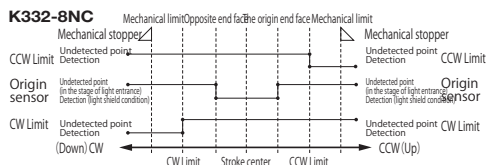
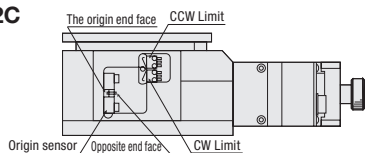

Unit [mm]	Reference coordinate	Mechanical limit	CW Limit	Opposite end face	Stroke center	The origin end face	CCW Limit	Mechanical limit
KS332-8NC	Return to origin	—	4.9	2.2	0.4	0	4.1	—
	Stroke center	—	4.5	1.8	0	0.4	4.5	—

\*Return to origin means that is performed return to origin Type 3 using DS102/DS112 series.  
 \* The coordinate value should be on the design. Dimension error may occur about plus or minus 0.5 mm.

Unit [mm]	Reference coordinate	Mechanical limit	CW Limit	Opposite end face	Stroke center	The origin end face	CCW Limit	Mechanical limit
KS332-12C	Return to origin	—	7.6	2.2	1.1	0	5.4	—
	Stroke center	—	6.5	1.1	0	1.1	6.5	—

\*Return to origin means that is performed return to origin Type 3 using DS102/DS112 series.  
 \* The coordinate value should be on the design. Dimension error may occur about plus or minus 0.5 mm.

Method for return to origin

Suruga's motorized stages is different from the sensor specifications depends on models. As return to origin operation is divided into types, it is necessary to choose the correct type. Selected wrong type may be operated uncorrectly.

Choose your best one whatever you need according to be recommended as below.

■ KHC06004F/KHC07004F/KS332-8NC/KS332-12C recommended return to origin Return to origin sequence ▶ P.1-201~

Type 3: Detect in the direction of CCW and perform detected process for CCW edge (a point) of ORG signal.

Type 4: Detect in the direction of CW and perform detected process for CW edge of ORG signal.

Type 9: After finished Type3, perform detected process for CCW edge of TIMING signal.

Type 10: After finished Type4, perform detected process for CW edge of TIMING signal.

Adaptive driver · Stepping motor controller

■ Driver ▶ P.1-205~

DC24 type input.....SD5107P3-A22 (Full/Half) / CRD5107P (1~1/250 16 steps) / DFC5107P

AC100V input.....RKD507-A (1~1/250 16 steps)

■ Controller ▶ P.1-197~

AC100-240V input Without general I/O port.....DS102NR (Full/Half) / DS102MS (1~1/250 16 steps)  
 With general I/O port.....DS102NR-IO (Full/Half) / DS102MS-IO (1~1/250 16 steps)

DC24V input Without general I/O port.....DS112NR (Full/Half) / DS112MS (1~1/250 16 steps)  
 With general I/O port.....DS112NR-IO (Full/Half) / DS112MS-IO (1~1/250 16 steps)