

Specification Of Oriental Motor α STEP Driver

Oriental Motor α STEP ARD-K

Driver Basic Specifications

Input Power Supply	DC24V±10%	
Velocity / Position Control Commands	Pulse Input	
Maximum Input Pulse Frequency	When the host controller is a line driver output: 500kHz (When pulse duty is 50%) When the host controller is an open-collector output: 250 kHz (When pulse duty is 50%)※1	
Protection Functions	When the alarms are activated, ALM Output OFF and motor stops. (The current of the motor is not interrupted only for the operation data abnormality alarm, the operation is continued.) [Over heat, Over load, Over speed, Command pulse error, Over voltage, Under voltage, Excessive position deviation alarm at current ON, Excessive position deviation alarm at current OFF, Operation data error, Electronic gear setting error, Sensor error of during operation, Sensor error of initial operation, Initial rotor rotation error, Rotation error, Motor combi error, EEPROM error]	
Input Signal	Photocoupler inputs • Insulation resistance DC5V: 200Ω, DC24V: 2.7kΩ [CW Pulse input/Pulse input(+5V/Line Driver), CW Pulse input/Pulse input(+24V) CCW Pulse input/Rotational direction input(+5V/Line Driver), CCW Pulse input/Rotational direction input(+24V)] • Insulation resistance DC5V~DC24V: 3.0kΩ [Current ON, Deviation counter clear/Reset of alarms, Current limit mode ON, Change of resolution, Drive for Return to origin, Reset of position, Energized OFF]	
Output Signal	• Photocoupler • Open collector output External use condition DC30V, 15mA or less [alarms, Warning, Positioning completion, Exercise Ready, Torque limit, Timing signal(Open collector)] • Line driver output 26C31 equivalent [A-phase power Pulse output(Line driver), B-phase power Pulse output(Line driver), Timing signal(Line driver)]	
Operating Environment	Operating Temperature	0~+50°C (No Freezing)
	Operating Humidity	85%RH or below (No Condensation)
	Ambience	No corrosive gases or dust. No direct contact with water or oil.

※1 Specs are use General-purpose cable(CC36D1-1).

※2 Not described insulation and dielectric strength, because of covered with a resin.

External Dimension Diagram

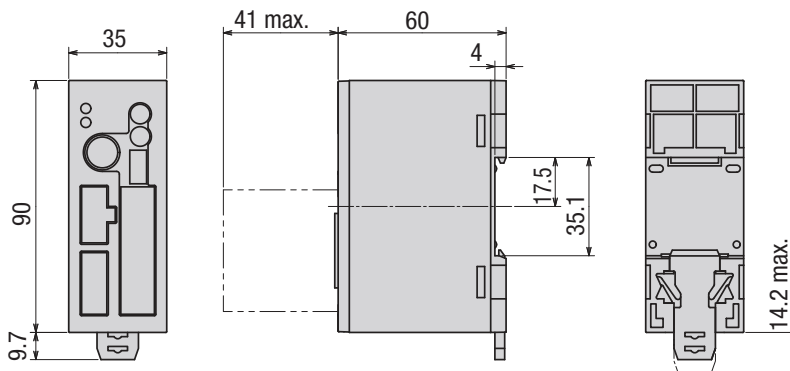

Oriental Motor α STEP ARD-A

Driver Basic Specifications

Input Power Supply		Single-phase AC100-115V -15~+10% 50/60Hz
Velocity / Position Control Commands		Pulse Input
Maximum Input Pulse Frequency		When the host controller is a line driver output: 500kHz (When pulse duty is 50%) When the host controller is an open-collector output: 250 kHz (When pulse duty is 50%)※1
Protection Functions		When the alarms are activated, ALM Output OFF and motor stops. (The current of the motor is not interrupted only for the operation data abnormality alarm, the operation is continued.) [Over heat, Over load, Over speed, Command pulse error, Regenerative resistor overheating, Over voltage, Main power supply error, Under voltage, Excessive position deviation alarm at current ON, Excessive position deviation alarm at current OFF, Over current, Power system circuit fault, Operation data error, Electronic gear setting error, Sensor error of during operation, Sensor error of initial operation, Initial rotor rotation error, Rotation error, Motor combi error, EEPROM error]
Input Signal		Photocoupler inputs • Insulation resistance DC5V: 200 Ω , DC24V: 2.7k Ω [CW Pulse input/Pulse input(+5V/Line Driver), CW Pulse input/Pulse input(+24V) CCW Pulse input/Rotational direction input(+5V/Line Driver), CCW Pulse input/Rotational direction input(+24V)] • Insulation resistance DC5V~DC24V: 3.0k Ω [Current ON, Deviation counter clear/Reset of alarms, Current limit mode ON, Change of resolution, Drive for Return to origin, Reset of position, Energized OFF]
Output Signal		• Photocoupler • Open collector output External use condition DC30V, 15mA or less [alarms, Warning, Positioning completion, Exercise Ready, Torque limit, Timing signal(Open collector)] • Line driver output 26C31 equivalent [A-phase power Pulse output(Line driver), B-phase power Pulse output(Line driver), Timing signal(Line driver)]
Insulation Resistance		100 M Ω or more when 500 VDC megger is applied between the following places • Protective Earth Terminal - Power supply • Signal I/O terminals - Power supply terminals
Dielectric Strength Voltage		Sufficient to withstand the following for 1 minute. • Protective Earth Terminal - Power supply terminals: AC1.5kV 50Hz or 60Hz • Signal I/O terminals - Power supply terminals: AC1.8kV 50Hz or 60Hz
Operating Environment (in Operation)	Operating Temperature	0~+50°C (No Freezing)
	Operating Humidity	85%RH or below (No Condensation)
	Ambience	No corrosive gases or dust. No direct contact with water or oil.

※1 Specs are use General-purpose cable(CC36D1-1).

※2 In case of set on the aluminium heat radiating plate, above 200×200×2mm.

External Dimension Diagram

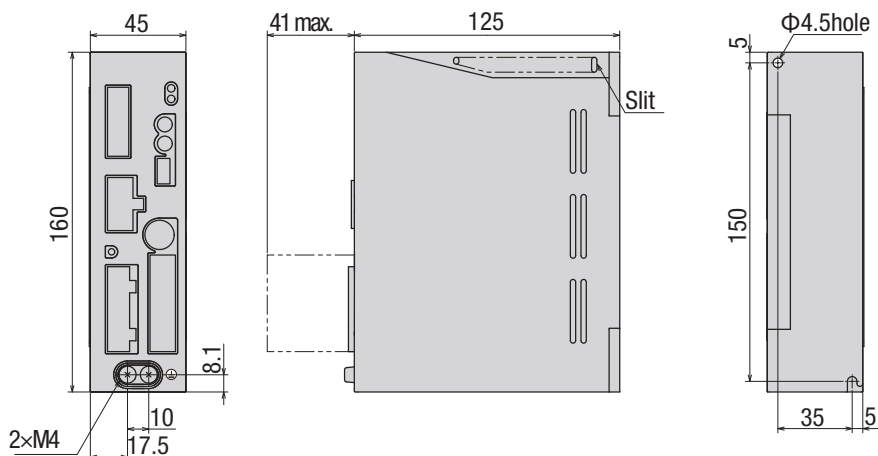

Specification Of Oriental Motor 5-phase Stepping Driver

Oriental Motor 5-phase Stepping Motors RKSD503-A (M-A) / RKSD507-A (M-A)

Driver Basic Specifications

Input Power Supply	Single-phase power:100-120V+10% 50/60Hz	
Velocity / Position Control Commands	Pulse Input	
Maximum Input Pulse Frequency	When the host controller is a line driver output:500kHz (When pulse duty is 50%) When the host controller is an open-collector output: 250 kHz (When pulse duty is 50%)*1	
Protection Functions	When an alarm occurs, the ALM output turns OFF, excitation of the motor is cut off, and holding torque disappears. At the same time the ALARME LED flashes. In the case of a motor with an electromagnetic brake, the electromagnetic brake is automatically held. [Over heat,Over voltage,Over speed,Over current,Over electric current,Voltage shortage,Error of auto control for electromagnetic brake,Error of electrolytic capacitor,EEPROM error,Error of CPU peripheral circuit.]	
Input Signal	Photocoupler Input signal voltage:11.4V~26.4V [AWO,CS,FREE,ALM-RST] Photocoupler Input signal voltage:3V~5.25V [CW(PLS)+5V,CCW(DIR)+5V] Photocoupler Input signal voltage:21.6V~26.4V [CW(PLS)+24V,CCW(DIR)+24V]	
Output Signal	Photocoupler • Open collector output External use condition :DC30V,10mA or less [REQDY,ALM,TIM]	
Function	When an alarm occurs, the ALM output turns OFF, excitation of the motor is cut off, and holding torque disappears. At the same time the ALARME LED flashes. In the case of a motor with an electromagnetic brake, the electromagnetic brake is automatically held. [Over heat,Over voltage,Over speed,Over current,Over electric current,Voltage shortage,Error of auto control for electromagnetic brake,Error of electrolytic capacitor,EEPROM error,Error of CPU peripheral circuit.]	
Insulation resistance	100 MΩ or more when 500 VDC megger is applied between the following places • Protective Earth Terminal - Power supply • Signal I/O terminals - Power supply terminals	
Withstand voltage	Sufficient to withstand the following for 1 minute. • Protective Earth Terminal - Power supply terminals:AC1.8kV 50Hz or 60Hz • Signal I/O terminals - Power supply terminals:AC1.9kV 50Hz or 60Hz	
Operating Environment	Operating Temperature	0~+50°C (No Freezing)
	Operating Humidity	85%RH or below (No Condensation)
	Ambience	No corrosive gases or dust. No direct contact with water or oil.

* 1 In case of set on the aluminium heat radiating plate,above 200×200×2mm.

* Electromagnetic type only

External Dimension Diagram

RKSD503-A (M-A)

RKSD507-A (M-A)

