

Motorized Goniometer Stage Guidance

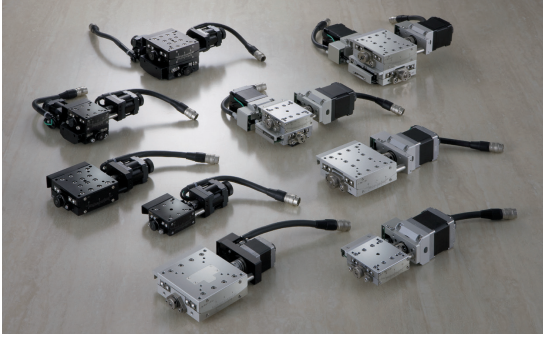

This is the arc driving stage which has center of rotation on the vertical centroid of the stage surface.

Usage

- Repeat positioning of minute angle in the optical pickup adjustment and inspection equipment.
- Parts posture adjusting for assembly process and mounting line.
- Available bonding camera lens and LCD panel together in production and inspection.

The focus of setting

Ball screw type

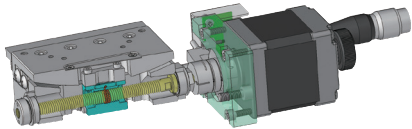

KGB/KAB Sinemotion Stage

▶ P.1-189~

High precision goniometer stage for driving minute angle repeatability.

Ball screw type is improved durability even continuing repeatability driving.

Table size	60×60mm	70×70mm

Worm gear type

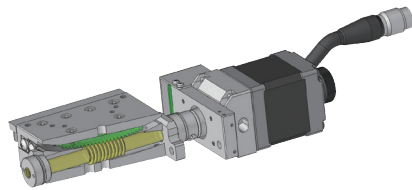

KG/KA/KGW/KAW

▶ P.1-205~

Our high precision goniometer stages based on cross roller guide for travel guide and worm gear mechanism. Selectable from various sizes and work distance type.

Table size	40×40mm	50×50mm	60×60mm	70×70mm

List of rotation centroid height

- Shows rotation centroid height for each stage surface.
- Mark of blue centroid can be integrated 2-axis.

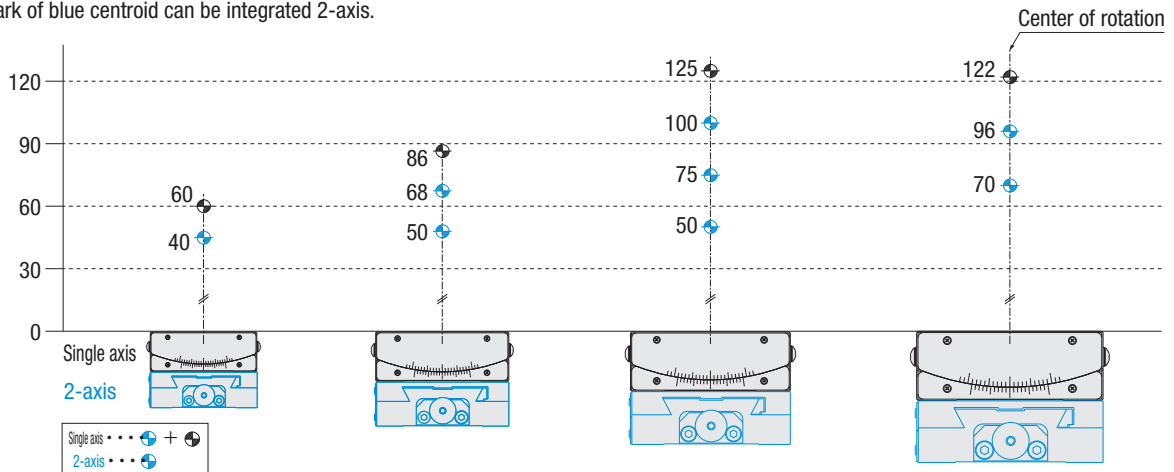
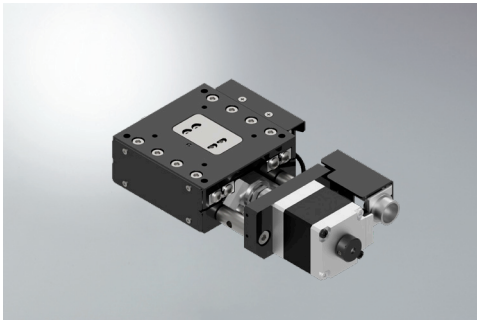

Table size	40×40	50×50	60×60	70×70
Ball screw type	—	—	○	○
Worm type	○	○	○	○

Ball bearing type sinemotion goniometer stages

High precision goniometer stages with ball bearings. This is ideal for driving a minute angle repeatability.

Features



High endurance

Backlash by the abrasion was concerned about by the worm gear type when continued being driven at a microangle repeatedly.

Ball screw mechanism makes evaluation high durability.

Improvement acceleration and deceleration

Smooth start-up and acceleration with small friction.

Reduction backlash

Using the preload parts may reduced backlash.

Travel length and isokinetic

The linear-driven will be changed to rotation-moving by using the internal bearing.

Ball screw traveling length will not be the same as stage travel angle due to linear-moving converts to rotation-moving.

It is different resolution per pulse at the center and end.

Rotation speed will not be constant even with the send of pulse signal at the constant speed.

Travel range calculation fomula

* The fomula based on the stroke center.

(1) Travel angle = $\text{Arcsin}(\text{Input pulse} \times X) / P$ (2) Input pulse = $P \times \sin(\text{Traveling angle}) / X$

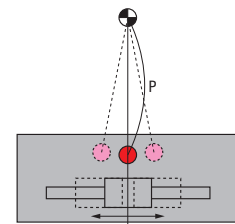

P=Distance between supporting points
(The distance between center rotation and bearing)

Terms

Definition	Value	Unit
Distance between supporting points P'	76	mm
Ball screw lead	1	mm
Motor basic step angle	0.72	°
Ball screw travel length per pulse X	0.002	mm

*Distance between supporting points depending on the stage.

Basic Specification

Model	Motor basic step angle	Distance between supporting points P
KGB06050	0.72°	55mm
KGB06075		80mm
KGB06100		105mm
KGB06125		130mm
KGB07070	0.72°	76mm
KGB07096		102mm
KGB07122		128mm

For use correctly

How to mount

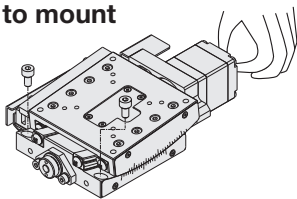

Stroke the upper plate to CW or CCW.

Screw on bolt holes for each 2. (Total 4 screws)

Tighten the screws by manual.

About object on the upper or lower stage.

Stage surface might be deformed and Mounting unflat object and set to the unflat place can affect to be deformed stage surface and decreasing accuracy.

Pay attention. [Approximate flatness: 10μm Within]

Position of stage mounting

All products SPEC shows must be shown flat setting condition.

Pay attention to mount such as up side down, vertical on the side and horizontal on the side.

Load capacity and accuracy might be changed by the positioning.

Please feel free to ask us for more information.

Each positioning characteristics

Travel guide [Feeding method]	Inverted and reversed	Side horizontal	Side vertical use
Crossed roller [Ball screw]	○	○	△
Crossed roller [Worm gear]	○	○	△

○ means usable, however load and moment is limited.

△ Load and moment is limited, it may not lose characteristics in some usage or models.

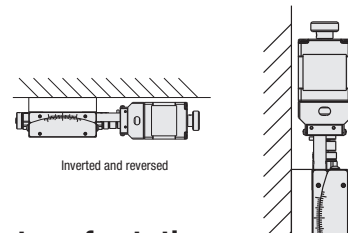

Run-out accuracy of the center of rotation/Height of the center of rotation

Our cross roller goniometer stages are providing high-precision machining.

Run-out accuracy of the center of rotation

Put the true sphere on the level of the center of rotation, and define the true sphere run-out as run-out accuracy of the center of rotation.

Height of the center of rotation

Height of the center of rotation is between upper side of stage and center of roundness.

Goniometer Stage Ball screw □60:KGB06/KAB06

KGB06050T-LC

KGB06050M-LC

KAB06050T-LC

KAB06050M-LC

RoHS

Freely
customize
the motor

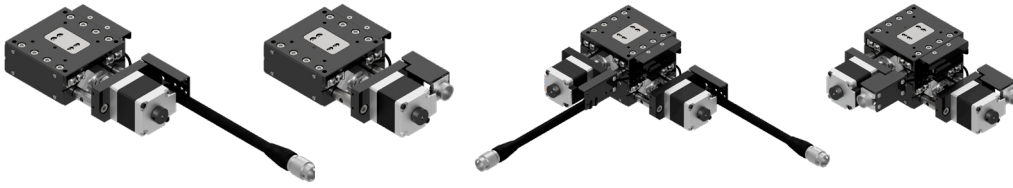

* All image is for illustrative purposes only.

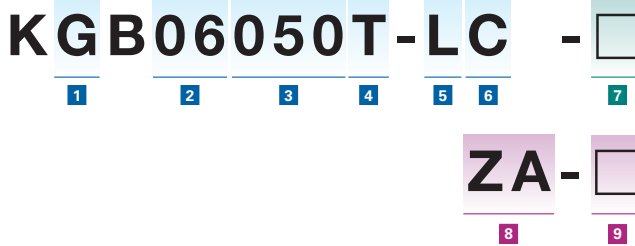

Calbes P.1-287~
Electrical specification P.1-201~

1 Axis

G	1-axis
A	2-axis

2 Table size

06	□60mm
----	-------

3 Height of center rotation (W.D.)

050	50mm
075	75mm
100	100mm
125	125mm

* 125mm height cannot be selected with KAB (2-axis).

4 Connector specifications

T	Pig tail	
M	Panel mount	

5 Sensor cover location specification

L	Lposition	
R	Opposite hand	

6 Motor option

Code	Specification
C	Standard(5 Phase stepping motor)
G	High resolution
T	2 Phase stepping motor

7 Cable option (for Motor: C·G·T)

Code	Specification	Cable type	Cable type
Blank	Cable is not included (Standard)		—
A	2m	D214-2-2E	—
B	2m One end loose	D214-2-2EK	DS1-2C-2-2EK
C	4m	D214-2-4E	—
D	4m One end loose	D214-2-4EK	DS1-2C-2-4EK
E	Only connector (Cable is not included)	—	—
F	Robot cable 2m	D214-2-2R	—
G	Robot cable 2m one end loose	D214-2-2RK	DS1-2C-2-2RK
H	Robot cable 4m	D214-2-4R	—
J	Robot cable 4m one end loose	D214-2-4RK	DS1-2C-2-4RK

Note:For T-phase stepping, only one end rose (B, D, G, J) is supported.

8 Motor option

Code	Specification
ZA	αSTEP (AZ Series)

9 Cable option (for Motor: ZA)

Code	Specification
Blank	Sensor cable 2m One end loose wire
3	Sensor cable 3m One end loose wire
5	Sensor cable 5m One end loose wire
3A	3A:Screwdriver (3m cable set)
5A	3A:Screwdriver (5m cable set)

* Motor option:Accessories when selecting ZA.

Cable option code	sensor cable model	motor cable model	Driver model
Blank	HR10AP-S-SB-6-2	—	—
3	HR10AP-S-SB-6-3	—	—
5	HR10AP-S-SB-6-5	—	—
3A	HR10AP-S-SB-6-3	CC030VZ2R2	AZD-K
5A	HR10AP-S-SB-6-5	CC050VZ2R2	AZD-K

Selection example

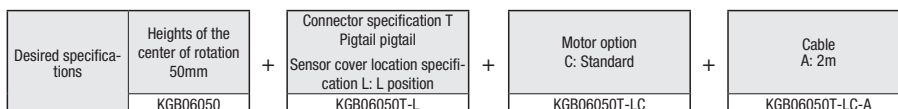

▷ KGB06040T-LC-A

X

XY

Z

Horizontal

Z

XYZ

Goniometer

Rotary

Unit

Controller

Ball
Screw

Worm
Gear

□40

□50

□60

□70

Specification

		SPEC							
Model		KGB06050□-LC	KGB06075□-LC	KGB06100□-LC	KGB06125□-LC	KAB06050□-RC	KAB06075□-RC	KAB06100□-RC	
Opposite hand		KGB06050□-RC	KGB06075□-RC	KGB06100□-RC	KGB06125□-RC	KAB06050□-LC	KAB06075□-LC	KAB06100□-LC	
Mechanical specification	Travel distance Upper/Lower axis	±8.5°	±5.5°	±5°	±4°	±8.5° /±5.5°	±5.5° /±5°	±5° /±4°	
	Stage table size	60×60mm							
	Travel mechanism (Reduction ratio)	Ball φ6 Lead 1							
	Guide	Cross roller guide							
	Main material—Surface finishing	Aluminum—Black alumite processing							
Dimensional tolerance	Weight	0.52kg				1.04kg			
	Height of stage	25± 0.2mm				50± 0.4mm			
	Height of center rotation	50± 0.2mm	75± 0.2mm	100± 0.2mm	125± 0.2mm	50± 0.4mm	75± 0.4mm	100± 0.4mm	
Accuracy specification	Center of rotation precision	0.01mm							
	Resolution/Pulse	Upper at the full	≒ 0.0021°	≒ 0.0014°	≒ 0.0011°	≒ 0.0009°	≒ 0.0021°	≒ 0.0014°	≒ 0.0011°
		Upper at the full	—				≒ 0.0014°	≒ 0.0011°	≒ 0.0009°
	MAX speed [15 kHz]	Upper	31.4°/sec	21.5°/sec	16.4°/sec	13.2°/sec	31.4°/sec	21.5°/sec	16.4°/sec
		Lower	—				21.5°/sec	16.4°/sec	13.2°/sec
	Repeatability positioning accuracy	±0.001°							
	Load capacity	5kgf [49N]				4.5kgf [44.1N]			
Moment stiffness	Pitch 0.30/yaw 0.10/roll 0.11[°/N · cm]					Pitch 0.41/yaw 0.2/roll 0.41[°/N · cm]			
Sensor	Lost motion	0.003°							
	Limit sensor	Available							
	Origin sensor	Available							
	Slit origin sensor	—							
Provided screw (Hexagon-headed bolt)		4 of M4—10							

* The SPEC varies depending on the motor.
 - For the exact calculation formula for the movement amount, please refer to P.1-188.

Resolution · MAX speed · Weight

Motor code	C	G	T	ZA	
Specification	Standard	High resolution	2 Phase stepping motor	αSTEP (AZ)	
Motor model ¹⁾	C005C-90215P-1	PK523HPMB-C1	SJA28N32-0674B-01	AZM24AK	
Step angle	0.72°	0.36°	1.8°	0.36° ^{※2}	
1 Axis Resolution (Full)	KGB06050T/M	≒ 0.0021°	≒ 0.0010°	≒ 0.0052°	≒ 0.0010° ^{※2}
	KGB06075T/M	≒ 0.0014°	≒ 0.0007°	≒ 0.0036°	≒ 0.0007° ^{※2}
	KGB06100T/M	≒ 0.0011°	≒ 0.0005°	≒ 0.0027°	≒ 0.0005° ^{※2}
	KGB06125T/M	≒ 0.0009°	≒ 0.0004°	≒ 0.0022°	≒ 0.0004° ^{※2}
1 Axis Resolution (Full) (Upper Lower)	KAB06050T/M	≒ 0.0021° ≒ 0.0014°	≒ 0.0010° ≒ 0.0007°	≒ 0.0052° ≒ 0.0036°	≒ 0.0010° ≒ 0.0007° ^{※2}
	KAB06075T/M	≒ 0.0014° ≒ 0.0011°	≒ 0.0007° ≒ 0.0005°	≒ 0.0036° ≒ 0.0027°	≒ 0.0007° ≒ 0.0005° ^{※2}
	KAB06100T/M	≒ 0.0011° ≒ 0.0009°	≒ 0.0005° ≒ 0.0004°	≒ 0.0027° ≒ 0.0022°	≒ 0.0005° ≒ 0.0004° ^{※2}
1 Axis MAX speed	KGB06050T/M	31.4°/sec [15kHz]	26.1°/sec [25kHz]	26.1°/sec [5kHz]	31.4°/sec [30kHz]
	KGB06075T/M	21.5°/sec [15kHz]	17.9°/sec [25kHz]	17.9°/sec [5kHz]	21.5°/sec [30kHz]
	KGB06100T/M	16.4°/sec [15kHz]	13.7°/sec [25kHz]	13.7°/sec [5kHz]	16.4°/sec [30kHz]
	KGB06125T/M	13.2°/sec [15kHz]	11.0°/sec [25kHz]	11.0°/sec [5kHz]	13.2°/sec [30kHz]
2 Axis MAX speed (Upper Lower)	KAB06050T/M	31.4° 21.5°/sec [15kHz]	26.1° 17.9°/sec [25kHz]	26.1° 17.9°/sec [5kHz]	31.4° 21.5°/sec [30kHz]
	KAB06075T/M	21.5° 16.4°/sec [15kHz]	17.9° 13.7°/sec [25kHz]	17.9° 13.7°/sec [5kHz]	21.5° 16.4°/sec [30kHz]
	KAB06100T/M	16.4° 13.2°/sec [15kHz]	13.7° 11.0°/sec [25kHz]	13.7° 11.0°/sec [5kHz]	16.4° 13.2°/sec [30kHz]
Weight ^{※3}	KGB06*T/M	0.52kg	0.52kg	0.52kg	0.56kg
	KAB06*T/M	1.04kg	1.04kg	1.04kg	1.12kg

※1 Model numbers include Suruga Seiki's proprietary management codes.
 ※2 1000P/R setting
 ※3 The weight of the pigtail/panel mount model is the same.

Motorized
goniometer Stage

X

XY

Z

Horizontal

Z

XYZ

Goniometer

Rotary

Unit

Controller

Ball
Screw

Worm
Gear

□40

□50

□60

□70

Goniometer Stage Ball screw □60:KGB06/KAB06

Dimensions (1-axis)

KGB06T-L Series

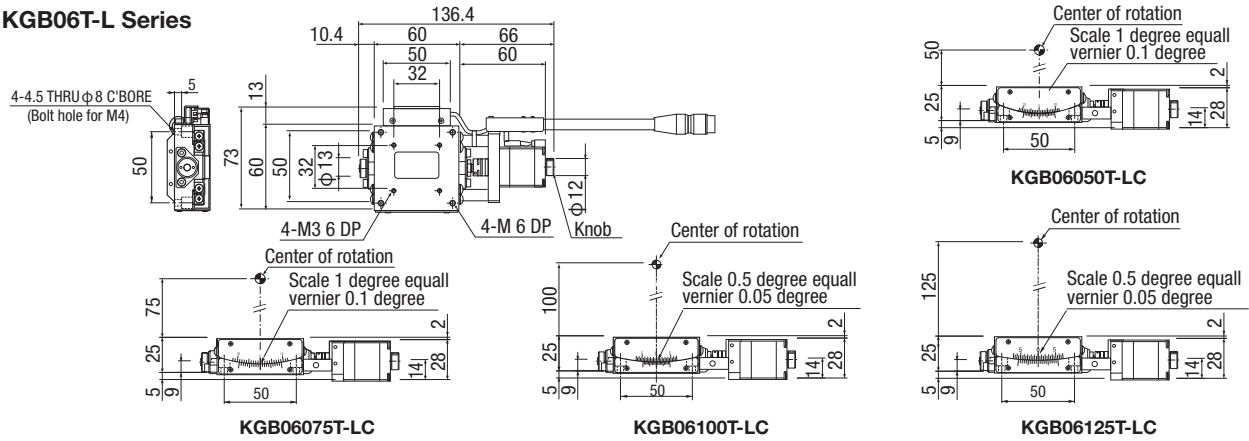

KGB06T-R Series (Opposite hand)

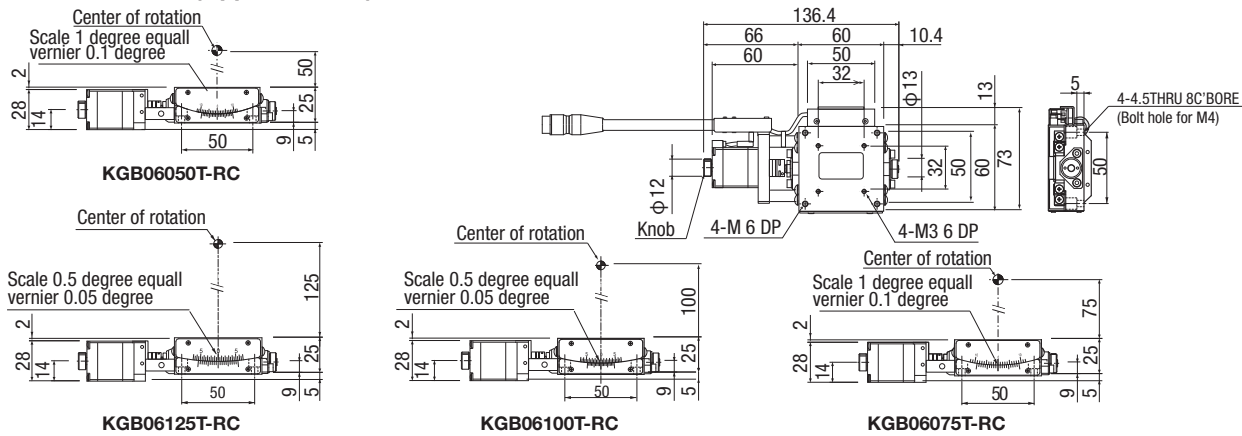

Dimensions (2-axis)

KAB06T-L-Series

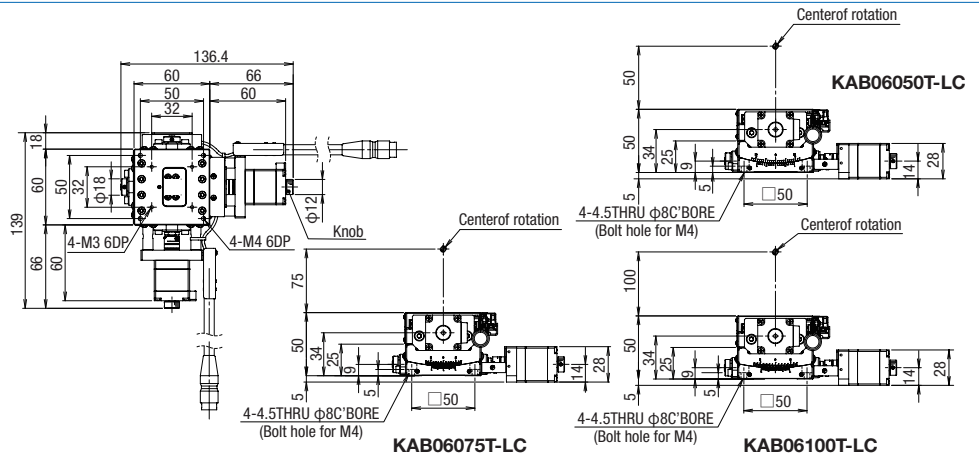

KAB06T-R Series (Opposite hand)

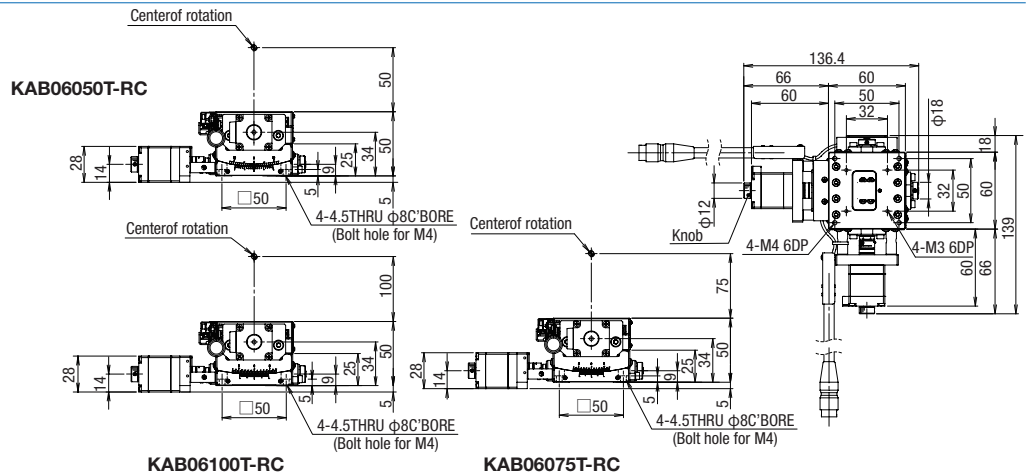

Motorized
goniometer Stage

X

XY

Z

Horizontal

Z

XYZ

Goniometer

Rotary

Unit

Controller

Ball
Screw

Worm
Gear

□40

□50

□60

□70

Dimensions (1-axis)

KGB06M-L Series

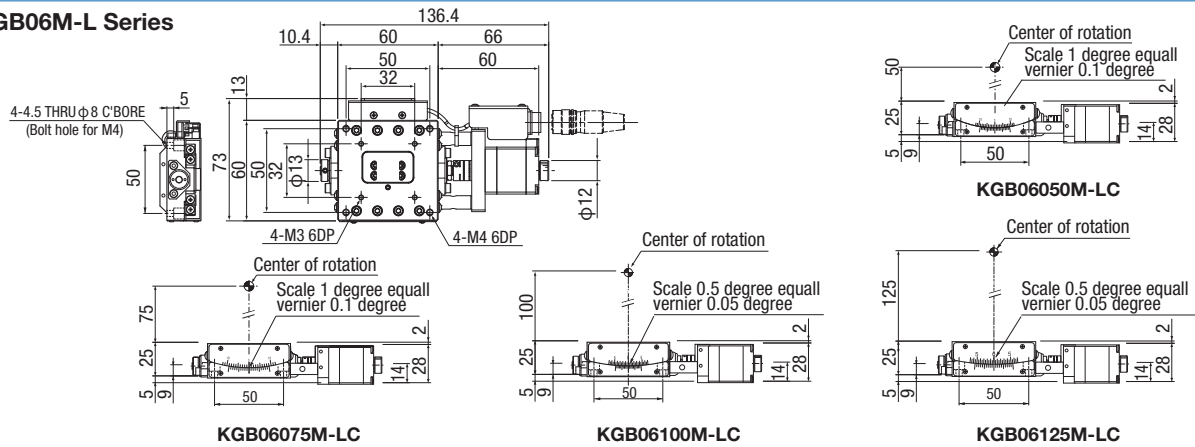

KGB06M-R Series (Opposite hand)

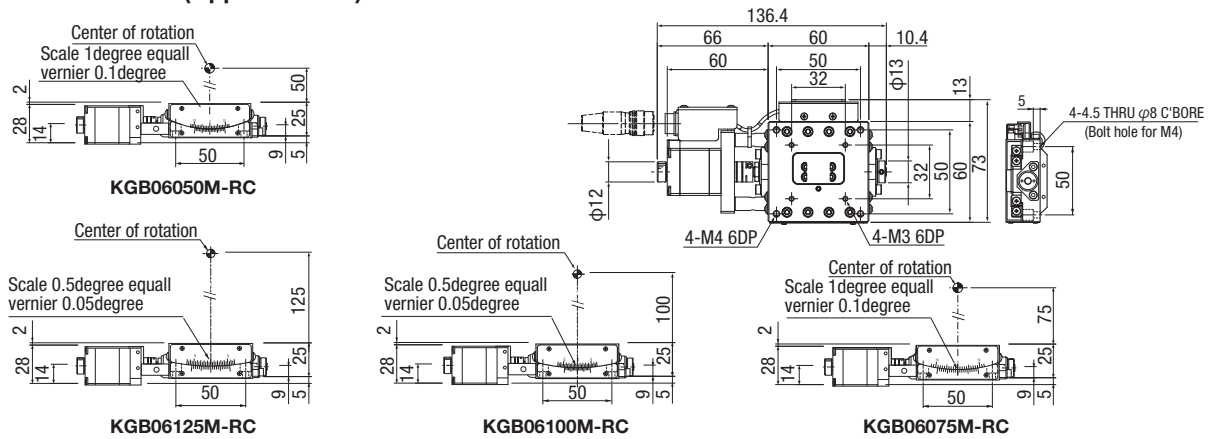

Dimensions (2-axis)

KAB06M-L Series

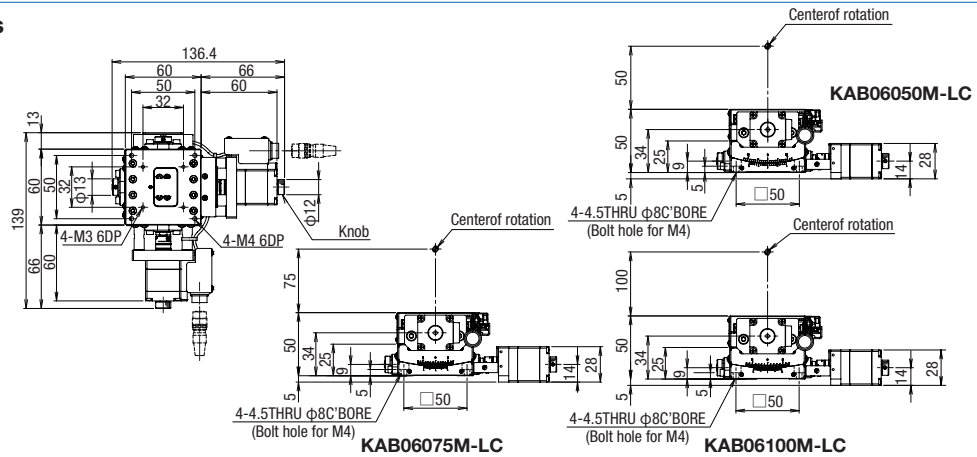

KAB06M-R Series (Opposite hand)

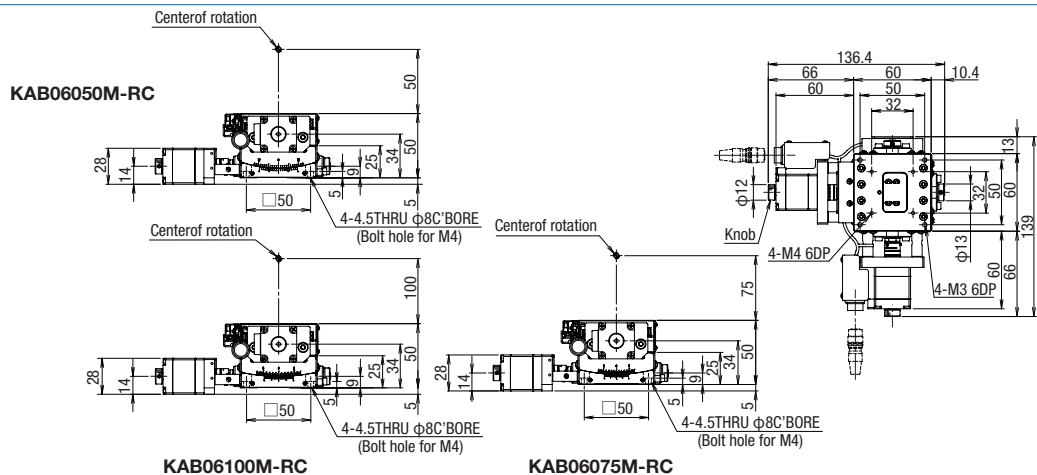

X

XY

Z

Horizontal

Z

XYZ

Goniometer

Rotary

Unit

Controller

Ball
Screw

Worm
Gear

□40

□50

□60

□70

Motorized Stage

Goniometer Stage Ball screw □60:KGB06

Dimensions

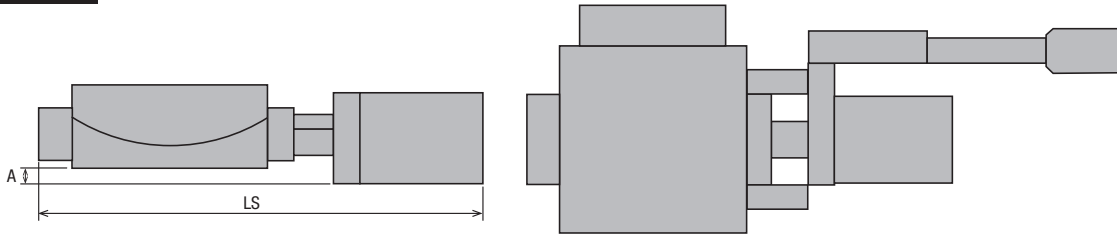

C Standard

Motor model C005C-90215P-1

G High resolution

Motor model PK523HPMB-C1

T 2相ステッピングモータ

Motor model SUW201320067001

Model	Motor	Motor size	Connector	A(mm)	LS(mm)
KGB06050T-□□	C • G • T	□ 28	T	5	136.4
KGB06075T-□□					
KGB06100T-□□					
KGB06125T-□□					
KGB06050M-□□			M		
KGB06075M-□□					
KGB06100M-□□					
KGB06125M-□□					

ZA αSTEP (AZ)

Motor model AZM24AK

Model	Motor	Motor size	Connector	A(mm)	LS(mm)
KGB06050T-□ZA	ZA	□ 28	T	5	159.4
KGB06075T-□ZA					
KGB06100T-□ZA					
KGB06125T-□ZA					
KGB06050M-□ZA			M		
KGB06075M-□ZA					
KGB06100M-□ZA					
KGB06125M-□ZA					

Motorized
goniometer Stage

X

XY

Z

Horizontal

Z

XYZ

Goniometer

Rotary

Unit

Controller

Ball
Screw

Worm
Gear

□40

□50

□60

□70

Motor option

C Standard motor
 Motor model
 C005C-90215P-1

G High resolution
 Motor model
 PK523HPMB-C1

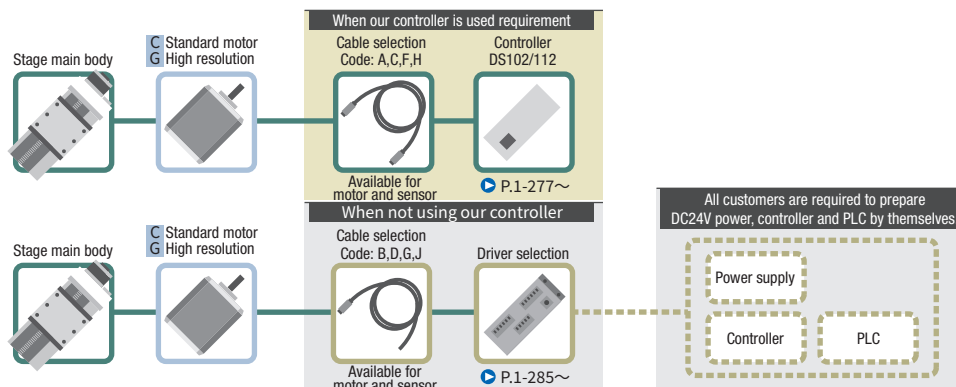

Motor option

T 2 Phase stepping motor
 Motor model
 SJA28N32-0674B-01

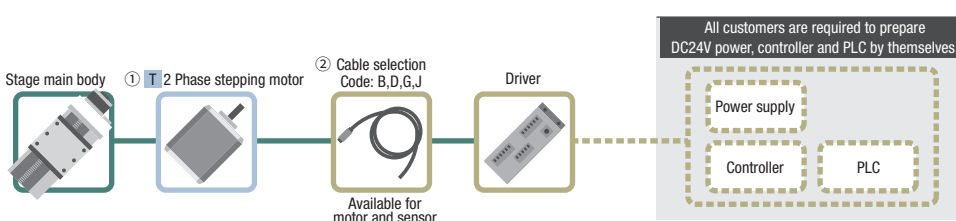

Code	① Motor model	② Motor + Sensor cable selection(common)
T	SJA28N32-0674B-01	B · D : DS1-2C-2-□EK G · J : DS1-2C-2-□RK

Motor option

ZA αSTEP (AZ Series)
 Motor model
 AZM24AK

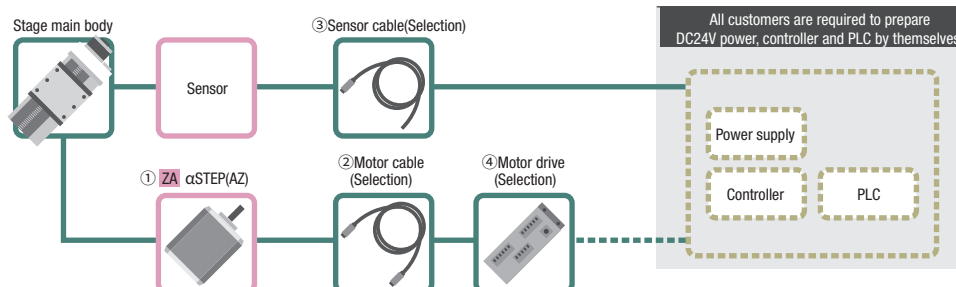

Code	① Motor model	② Motor cable selection	③ Sensor cable selection	④ Driver selection
ZA	AZM24AK	3A : CC030VZ2R2 5A : CC050VZ2R2 Blank · 3 · 5 : None	3A · 3 : HR10AP-S-SB-6-3 5A · 5 : HR10AP-S-SB-6-5 Blank : HR10AP-S-SB-6-2	3A · 5A : AZD-K Blank · 3 · 5 : None

- X
- XY
- Z
- Horizontal Z
- XYZ
- Goniometer
- Rotary
- Unit
- Controller

Ball Screw

Worm Gear

□40

□50

□60

□70

Goniometer Stage Ball screw □70:KGB07/KAB07

KGB07070AT-LC

KGB07070AM-LC

KAB07070AT-LC

KAB07070AM-LC

RoHS

Freely
customize
the motor

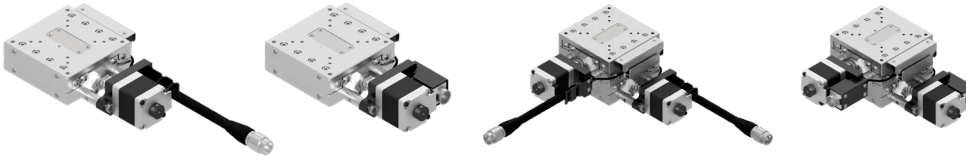

* All image is for illustrative purposes only.

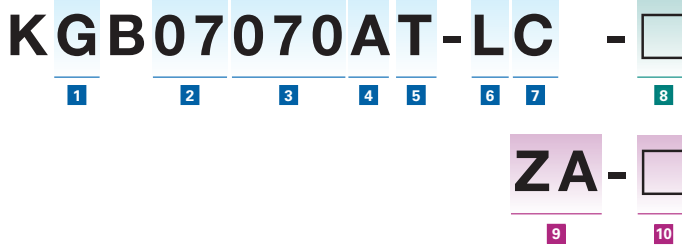

Calbes P.1-287~
Electrical specification P.1-201~

1 Axis

G	1-axis
A	2-axis

2 Table size

07	□70mm
----	-------

3 Height of center rotation (W.D.)

070	70mm
096	96mm
122	122mm * Excluding KAB (2-axis)

4 Sensor logic

Code	CWLS	ORG	CCWLS
A	N.C.	N.C.	N.C.
B	N.O.	N.O.	N.O.
C	N.C.	N.O.	N.C.

5 Connector specifications

T	Pig tail	
M	Panel mount	

6 Sensor cover location specification

L	L position	
R	Opposite hand	

7 Motor option

Code	Specification
C	Standard(5 Phase stepping motor)
G	High resolution
T	2 Phase stepping motor

8 Cable option (Motor: C·G·T)

Code	Specification	Cable type	2 phase Cable type
Blank	Cable is not included (Standard)	—	—
A	2m	D214-2-2E	—
B	2m One end loose	D214-2-2EK	DS1-2C-2-2EK
C	4m	D214-2-4E	—
D	4m One end loose	D214-2-4EK	DS1-2C-2-4EK
E	Only connector (Cable is not included)	—	—
F	Robot cable 2m	D214-2-2R	—
G	Robot cable 2m one end loose	D214-2-2RK	DS1-2C-2-2RK
H	Robot cable 4m	D214-2-4R	—
J	Robot cable 4m one end loose	D214-2-4RK	DS1-2C-2-4RK

Note:For T-phase stepping, only one end rose (B, D, G, J) is supported.

9 Motor option

Code	Specification
ZA	αSTEP (AZ Series)

10 Cable option (Motor: ZA)

Code	Specification
Blank	Sensor cable 2m One end loose wire
3	Sensor cable 3m One end loose wire
5	Sensor cable 5m One end loose wire
3A	3A:Screwdriver (3m cable set)
5A	3A:Screwdriver (5m cable set)

* Motor option: Accessories when ZA is selected.

Cable option code	Sensor cable model	Sensor cable model	Driver model
Blank	HR10AP-S-SB-6-2	—	—
3	HR10AP-S-SB-6-3	—	—
5	HR10AP-S-SB-6-5	—	—
3A	HR10AP-S-SB-6-3	CC030V2R2	AZD-K
5A	HR10AP-S-SB-6-5	CC050V2R2	AZD-K

Selection example

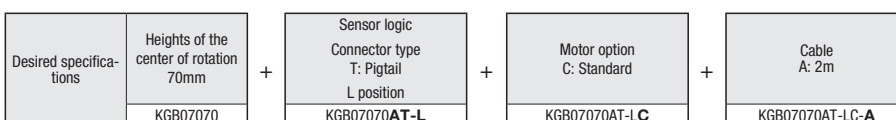

KGB07070AT-LC-A

Motorized
goniometer Stage

X

XY

Z

Horizontal

Z

XYZ

Goniometer

Rotary

Unit

Controller

Ball
Screw

Worm
Gear

□40

□50

□60

□70

Specification

SPEC							
Model		KGB07070A□-LC	KGB07096A□-LC	KGB07122A□-LC	KAB07070A□-LC	KAB07096A□-LC	
Opposite hand		KGB07070A□-RC	KGB07096A□-RC	KGB07122A□-RC	KAB07070A□-RC	KAB07096A□-RC	
Mechanical specification	Travel distance Upper/Lower axis	±5°	±4°	±3°	±5°/±4°	±4°/±3°	
	Stage table size	70×70mm					
	Travel mechanism (Reduction ratio)	Ball φ6 Lead 1					
	Guide	Cross roller guide					
	Main material—Surface finishing	Aluminum—White alumite processing					
Dimensional tolerances	Weight	0.67kg			1.34kg		
	Height of stage	26±0.2mm			52±0.4mm		
	Height of center rotation	70±0.2mm	96±0.2mm	122±0.2mm	70±0.4mm	96±0.4mm	
	Center of rotation precision	0.01mm			—		
Accuracy specification	Resolution/Pulse	Upper at the full	≒0.0015°	≒0.0011°	≒0.0009°	≒0.0015°	≒0.0011°
		Upper at the full	—			≒0.0011°	≒0.0009°
	MAX speed (15 kHz)	Upper	22.6°/sec	16.9°/sec	13.4°/sec	22.6°/sec	16.9°/sec
		Lower	—			16.9°/sec	13.4°/sec
	Repeatability positioning accuracy	±0.003°					
Load capacity	5.0kgf [49N]			4.0kgf [39.2N]			
Sensor	Moment stiffness	Pitch 0.28/yaw 0.06/roll 0.06["/N · cm]			Pitch 0.34/yaw 0.12/roll 0.34["/N · cm]		
	Lost motion	0.003°					
	Limit sensor	Available					
	Origin sensor	Available					
	Slit origin sensor	—					
Provided screw (Hexagon-headed bolt)		4 of M4—8					

※ Might be changed specification due to motors.

※ For the exact calculation formula for the movement amount, please refer to page 1-188.

※ The maximum speed is the theoretical speed when driven at 15kHz for the full stroke travel pulse.

Resolution · MAX speed · Weight

Motor code		C	G	T	ZA
Specification		標準	高分解能	2相ステッピングモータ	αSTEP (AZ)
Motor model ¹		C005C-90215P-1	PK523HPMB-C1	SJA28N32-0674B-01	AZM24AK
Step angle		0.72°	0.36°	1.8°	0.36° ^{※2}
1 Axis Resolution (Full)	KGB07070□T/M	≒0.0015°	≒0.0008°	≒0.0038°	≒0.0008° ^{※2}
	KGB07096□T/M	≒0.0011°	≒0.0006°	≒0.0028°	≒0.0006° ^{※2}
	KGB07122□T/M	≒0.0009°	≒0.0004°	≒0.0022°	≒0.0004° ^{※2}
2 Axis Resolution (Full) (Upper Lower)	KAB07070□T/M	≒0.0015° ≒0.0011°	≒0.0008° ≒0.0006°	≒0.0038° ≒0.0028°	≒0.0008° ≒0.0006° ^{※2}
	KAB07096□T/M	≒0.0011° ≒0.0009°	≒0.0006° ≒0.0004°	≒0.0028° ≒0.0022°	≒0.0006° ≒0.0004° ^{※2}
1 Axis MAX speed	KGB07070□T/M	22.6°/sec [15kHz]	18.9°/sec [25kHz]	18.9°/sec [5kHz]	22.6°/sec [30kHz]
	KGB07096□T/M	16.9°/sec [15kHz]	14.1°/sec [25kHz]	14.1°/sec [5kHz]	16.9°/sec [30kHz]
	KGB07122□T/M	13.4°/sec [15kHz]	11.2°/sec [25kHz]	11.2°/sec [5kHz]	13.4°/sec [30kHz]
2 Axis MAX speed (Upper Lower)	KAB07070□T/M	22.6° 16.9°/sec [15kHz]	18.9° 14.1°/sec [25kHz]	18.9° 14.1°/sec [5kHz]	22.6° 16.9°/sec [30kHz]
	KAB07096□T/M	16.9° 13.4°/sec [15kHz]	14.1° 11.2°/sec [25kHz]	14.1° 11.2°/sec [5kHz]	16.9° 13.4°/sec [30kHz]
Weight ^{※3}	KGB07*T/M	0.67kg	0.67kg	0.67kg	0.71kg
	KAB07*T/M	1.34kg	1.34kg	1.34kg	1.42kg

*1 Model numbers include Suruga Seiki's proprietary management codes.

*2 1000P/R setting

*3 The weight of the pigtail/panel mount model is the same.

Motorized
goniometer Stage

X

XY

Z

Horizontal

Z

XYZ

Goniometer

Rotary

Unit

Controller

Ball
Screw

Worm
Gear

□40

□50

□60

□70

1

196

Motorized Stage

Goniometer Stage Ball screw □70:KGB07/KAB07

Dimensions (1-axis)

KGB07T-L Series

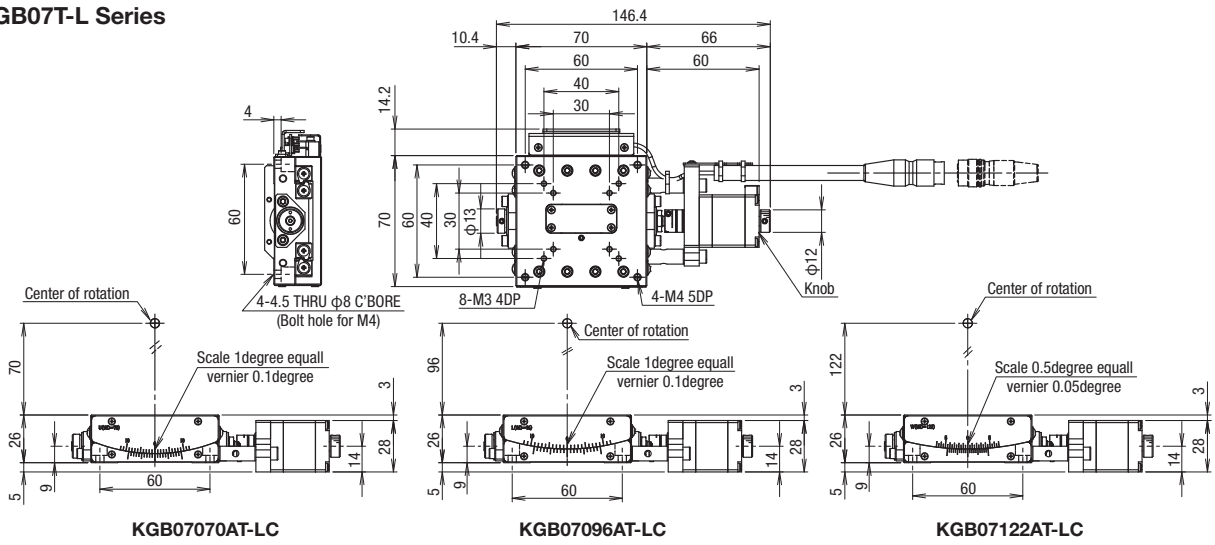

KGB07T-R Series

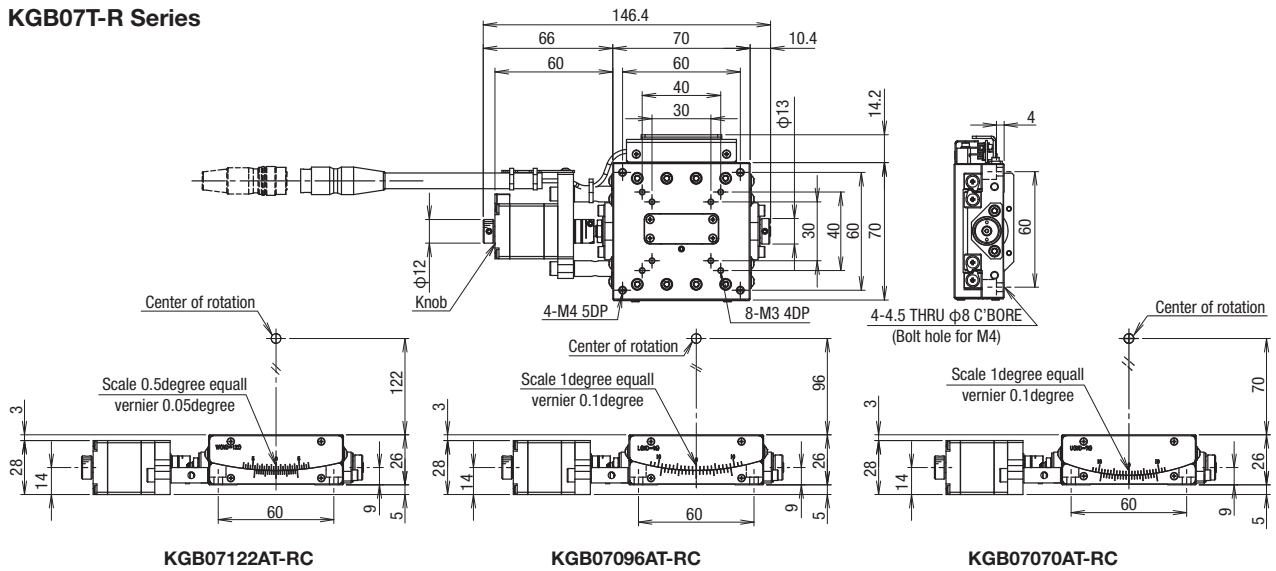

Dimensions (2-axis)

KAB07T-L Series

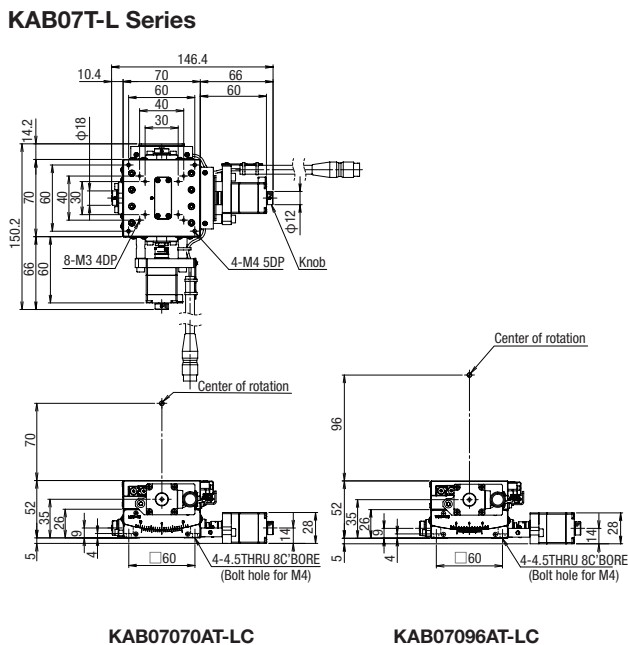

KAB07T-R Series

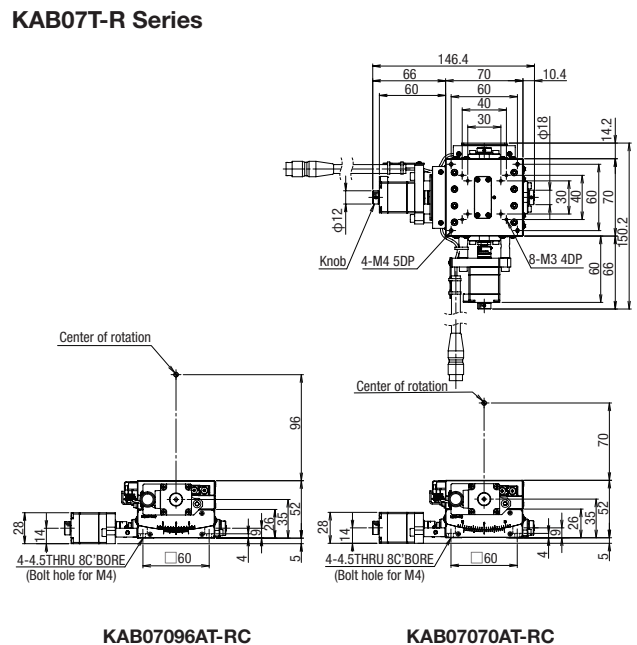

Motorized
goniometer Stage

X

XY

Z

Horizontal

Z

XYZ

Goniometer

Rotary

Unit

Controller

Ball
Screw

Worm
Gear

□40

□50

□60

□70

1

Motorized Stage

Goniometer Stage Ball screw □70:KGB07

Dimensions

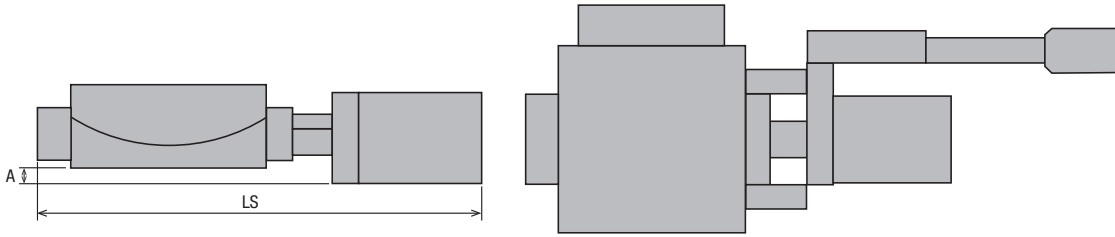

C Standard

Motor model C005C-90215P-1

G High resolution

Motor model PK523HPMB-C1

T 2 Phase stepping motor

Motor model SJA28N32-0674B-01

Model	Motor	Motor size	Connector	A(mm)	LS(mm)
KGB07070□T-□□	C • G • T	□ 28	T	5	146.4
KGB07096□T-□□					
KGB07122□T-□□					
KGB07070□M-□□			M		
KGB07096□M-□□					
KGB07122□M-□□					

ZA αSTEP (AZ)

Motor model AZM24AK

Model	Motor	Motor size	Connector	A(mm)	LS(mm)
KGB07070□T-□□	ZA	□ 28	T	5	169.4
KGB07096□T-□□					
KGB07122□T-□□					
KGB07070□M-□□			M		
KGB07096□M-□□					
KGB07122□M-□□					

Motorized
goniometer Stage

X

XY

Z

Horizontal

Z

XYZ

Goniometer

Rotary

Unit

Controller

Ball
Screw

Worm
Gear

□40

□50

□60

□70

Motor option

C Standard motor
 Motor model
 C005C-90215P-1

G High resolution
 Motor model
 PK523HPMB-C1

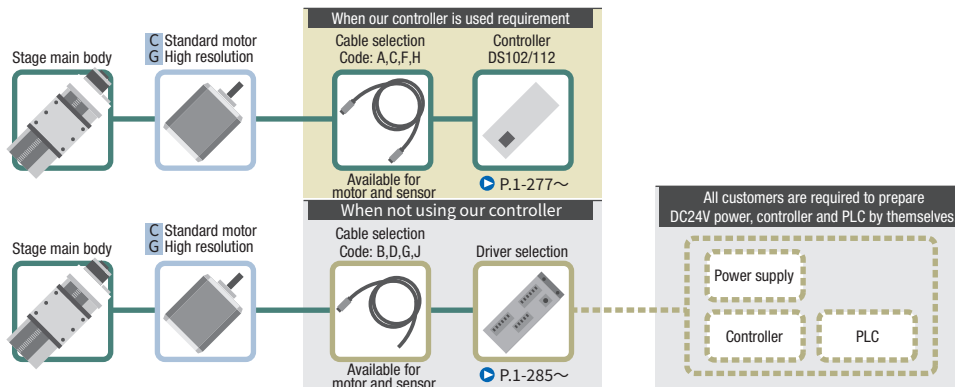

Motor option

T 2 Phase stepping motor
 Motor model
 SJA28N32-0674B-01

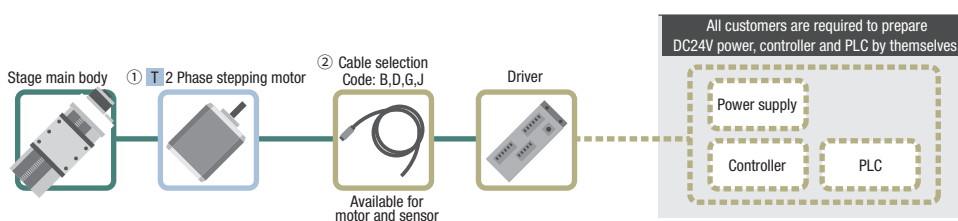

Code	①Motor model	②Motor/sensor cable selection	③Driver selection
T	SJA28N32-0674B-01	B · D : DS1-2C-2-□EK G · J : DS1-2C-2-□RK	AD1421

Motor option

ZA αSTEP (AZ Series)
 Motor model
 AZM24AK

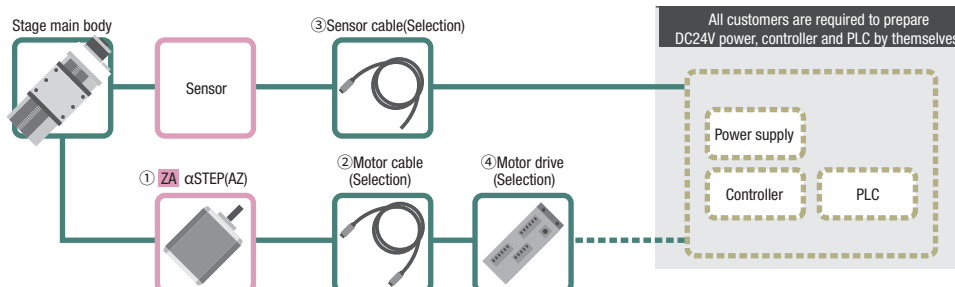

Code	①Motor model	② Motor cable selection	③ Sensor cable selection	④ Driver selection
ZA	AZM24AK	3A : CC030VZ2R2 5A : CC050VZ2R2 None · 3 · 5 : None	3A · 3 : HR10AP-S-SB-6-3 5A · 5 : HR10AP-S-SB-6-5 Blank : HR10AP-S-SB-6-2	3A · 5A : AZD-K None · 3 · 5 : None

- X
- XY
- Z
- Horizontal Z
- XYZ
- Goniometer
- Rotary
- Unit
- Controller

Ball Screw

Worm Gear

- 40
- 50
- 60
- 70

Electrical Specification: KGB Series

Electrical specification(5 Phase/2 Phase stepping motor)

Motor code		C	G	T	
Stage model		KGB06050/KGB06075/KGB06100/KGB06125/KGB07070/KGB07096/KGB07122			
Motor Specification (*1)	Type	5 phase stepping motor (0.75A/Phase)		2 phase stepping motor (0.67A/Phase)	
	Feature	Standard	High resolution	—	
	Model*2	C005C-90215P-1	PK523HPMB-C1	SJA28N32-0674B-01	
	With electromagnetic brake	—	—	—	
	Manufacturer	Oriental Motor Co., Ltd.		SURUGA SEIKI	
	Step angle	0.72°	0.36°	1.8°	
	mass		0.11kg		
	Motor size	□ size		□28mm	
		L size		37mm	
	Excitation (moment) maximum torque	0.048N · m	0.038N · m	0.059N · m	
Driver model	CVD507-K-A9(Oriental Motor Co., Ltd.)				
Driver power input	DC24V±10% 1.4A(MAX)				
Brake power input	—				
Connector	Pig tail	HR10A-10J-12P(73) (HRS)		HR10A-10J-10P(73) (HRS)	
	Panel mount	HR10A-10R-12P(73) (HRS)		HR10A-10R-10P(73) (HRS)	
	Receiving connector	HR10A-10P-12S(73) (HRS)		HR10A-10P-10S(73) (HRS)	
Sensor board	Limit sensor		Available		
	Origin sensor		Available		
	Sift origin sensor		—		
	Sensor	Photo microsensor EE-SX4320 (Omron Co., Ltd.)			
	Power-supply voltage	DC5~24V±5%			
	Current consumption	Total 60mA or less			
	Control output	NPN open collector output DC30V 10mA or less			
	Output logic	KGB06	On detection (light shield condition): Output transistor OFF (Non-continuity)		
			Sensor logic option A	On detection : Output transistor OFF (Non-continuity)	
		KGB07	Sensor logic option B	On detection : Output transistor ON (Continuity)	
Sensor logic option C			When limit is detected: Output transistor OFF (Non-continuity) When returning to origin: Output transistor ON (Continuity)		

* 1 P.1-297~ for details of single motor specification.

* 2 Model numbers include Suruga Seiki's proprietary management codes.

* 2 axis gonio (KAB) also has the same electrical specifications.

Pin allocation · Connection diagram

	Available for motor and sensor	□ 60		□ 70	
		Pin allocation	Connection diagram	Pin allocation	Connection diagram
G · C	Available for motor and sensor Pigtail connector model HR10A-10J-12P(73) (HRS) Panel mount specification : Connector model HR10A-10R-12P(73) (HRS)				
T	Available for motor and sensor Pigtail connector model HR10A-10J-10P(73) (HRS) Panel mount specification : Connector model HR10A-10R-10P(73) (HRS)				

Motorized
goniometer Stage

X

XY

Z

Horizontal

Z

XYZ

Goniometer

Rotary

Unit

Controller

Ball
Screw

Worm
Gear

□ 40

□ 50

□ 60

□ 70

Electrical specification (αSTEP AZ Series)

Motor code		ZA		
Stage model		KGB06050/KGB06075/KGB06100/KGB06125/KGB07070/KGB07096/KGB07122		
Motor Specification (*1)	Type	αSTEP (AZ Series)		
	Feature	Small step-out ,absolute		
	Model*2	AZM24AK		
	With electromagnetic brake	-		
	Manufacturer	Oriental Motor Co., Ltd.		
	Step angle	0.36° (1000P/R setting)		
	mass	0.15kg		
	Motor size	□ size	28mm	
		L size	45mm	
	Excitation (moment) maximum torque	0.095N · m		
	Driver model	AZD-(Oriental Motor Co., Ltd.)		
Driver power input	DC24V±5%			
Brake power input	-			
Connector	Pig tail	Motor: DF62B-13EP-2.2C (Hirose Electric Co., Ltd.) Sensor: HR10A-7J-6P(73) (Hirose Electric Co., Ltd.)		
	Panel mount	Motor: DF62B-13EP-2.2C (Hirose Electric Co., Ltd.) Sensor: HR10A-7R-6P(73) (Hirose Electric Co., Ltd.)		
	Receiving connector	Motor: DF62C-13S-2.2C (Hirose Electric Co., Ltd.) Sensor: HR10A-7P-6S(73) (Hirose Electric Co., Ltd.)		
Sensor board	Limit sensor	Available		
	Origin sensor	Available		
	Slit origin sensor	-		
	Sensor	Photo microsensor EE-SX4320 (Omron Co., Ltd.)		
	Power-supply voltage	DC5~24V±5%		
	Current consumption	Total 60mA or less		
	Control output	NPN open collector output DC30V 10mA or less		
	Output logic	KGB06	On detection (light shield condition): Output transistor OFF (Non-continuity)	
			Sensor logic option A	On detection : Output transistor OFF (Non-continuity)
		KGB07	Sensor logic option B	On detection : Output transistor ON (Continuity)
Sensor logic option C			When limit is detected: Output transistor OFF (Non-continuity) When returning to origin: Output transistor ON (Continuity)	

* 1 □ P.1-297~ for details of single motor specification.

* 2 Model numbers include Suruga Seiki's proprietary management codes.

* 2 axis gonio (KAB) also has the same electrical specifications.

Pin allocation · Connection diagram

Motor	<p>【Receiver cable】Model : CC030VZ2R2(3m)/CC050VZ2R2(5m)※Flexible cable</p>	
	ZA	<p>【Receiver cable】Model : HR10AP-S-SB-6-□ ※ □ : 2(2m)/3(3m)/5(5m) * Fixed</p> <p>Sensor side Connector (Female): HR10A-7P-6S (73) (HRS) ULAWM20276 AWG28 3P Black</p>
Sensor	□60	<p>【Stage connection diagram】Pigtail connector model : HR10A-7J-6P(73)(HRS) Panel mount specification : Connector model : HR10A-7R-6P(73)(HRS)</p>
	□70	<p>【Stage connection diagram】Pigtail connector model : HR10A-7J-6P(73)(HRS) Panel mount specification : Connector model : HR10A-7R-6P(73)(HRS)</p>

*The shields are connected with the connector shell.

Shield Color	Pin	Signals
Orange/Black	1	CWLS
Orange/Red	2	CCWLS
Gray/Black	3	ORG
Gray/Red	4	NORG
White/Black	5	V+
White/Red	6	V-
Shield		

Electrical specification: KGB Series

Timing chart

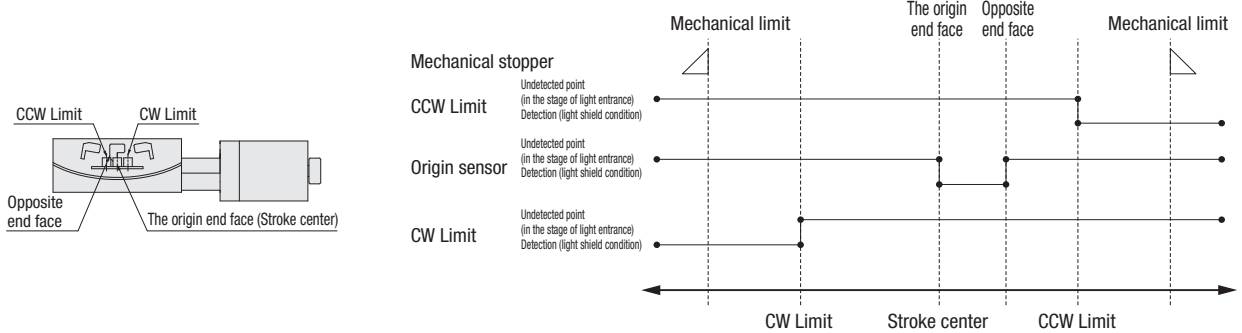

単位 [deg.]	Direction of CW ← → Direction of CCW					
	Reference coordinate	CW Limit	The origin end face Stroke center	Opposite end face	CCW Limit	
X	KGB06050	Return to origin	8.7	0	2.5	8.7
XY	KGB06075	Return to origin	5.7	0	1.8	5.7
Z	KGB06100	Return to origin	5.2	0	1.4	5.2
Horizontal Z	KGB06125	Return to origin	4.2	0	1.1	4.2
XYZ	KGB07070	Return to origin	5.3	0	2.1	5.3
Goniometer	KGB07096	Return to origin	4.2	0	1.5	4.2
Rotary	KGB07122	Return to origin	3.2	0	1.3	3.2

* Return to origin means that is performed return to origin type 4 using DS102/DS112 series.

* The coordinate is a basis of design value. Dimension error may occur about plus or minus 0.5 deg.

Note: The timing chart shows only timing of sensor, it is not for output signal logic.

Refer to ON/OFF display of output transistor that shows on electrical specifications-sensor-output logic for output signal logic.

Return to origin

Suruga's motorized stages is different from the wire connection as the number of sensors depending on models. It is necessary to choose type to suit correctly as return to origin operation is divided into same types. Selected wrong type may be operated incorrectly. Choose your best one whatever you need according to be recommended as below.

■ KGB06/KAB06/KGB07/KAB07 recommended return to origin Return to origin sequence [P.1-281~](#)

Type 3: Detect in the direction of CCW and perform detected process for CCW edge of ORG signal.

Type 4: Detect in the direction of CW and perform detected process for CW edge of ORG signal.

Type 9: After finished Type3, perform detected process for CCW edge of TIMING signal.

Type 10: After finished Type4, perform detected process for CW edge of TIMING signal.

[Type3] Detect in the direction of CCW and perform detected process for CCW edge (a point) of ORG signal.

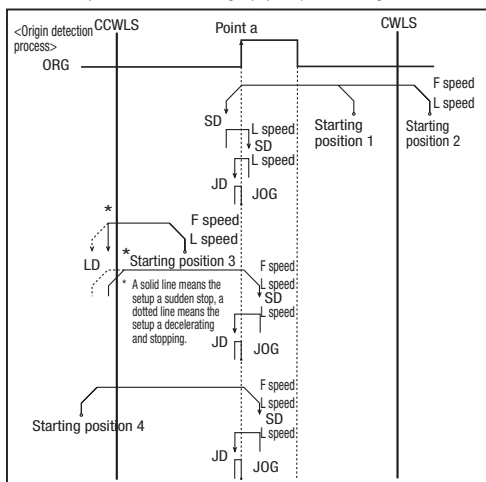

[Type4] Detect in the direction of CW and perform detected process for CW edge of ORG signal.

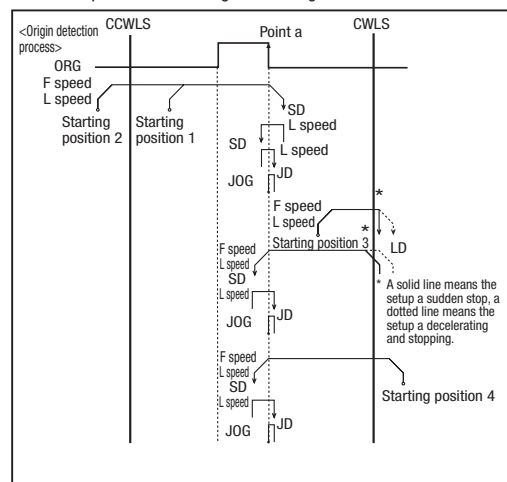

X

XY

Z

Horizontal
Z

XYZ

Goniometer

Rotary

Unit

Controller

Ball
Screw

Worm
Gear

40

50

60

70

Connectin example

■ Connection example 1 Motorized Stage 1axis: When holding a terminal device (using control software)

*USB cable connection between PC and controller.

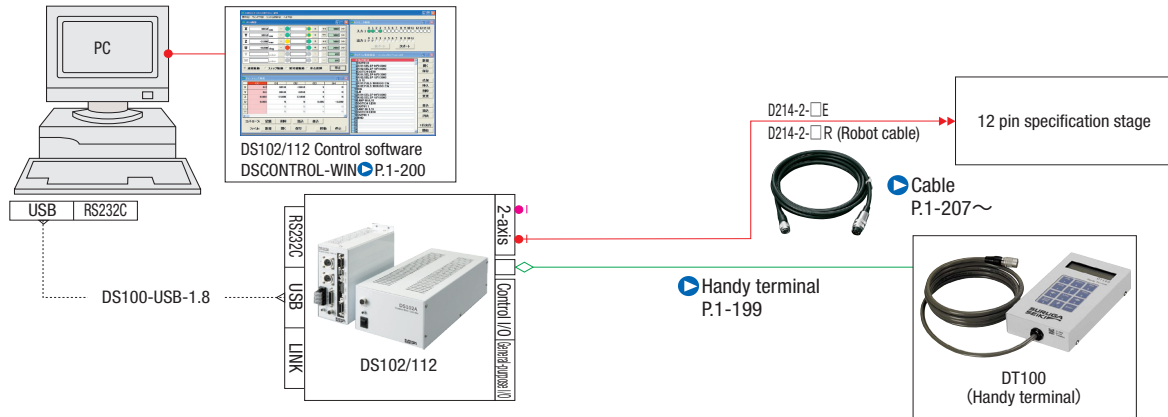

■ Connection example 2 Motorized Stage 4axis: When holding a terminal device (using control software)

*USB cable connection between PC and controller.

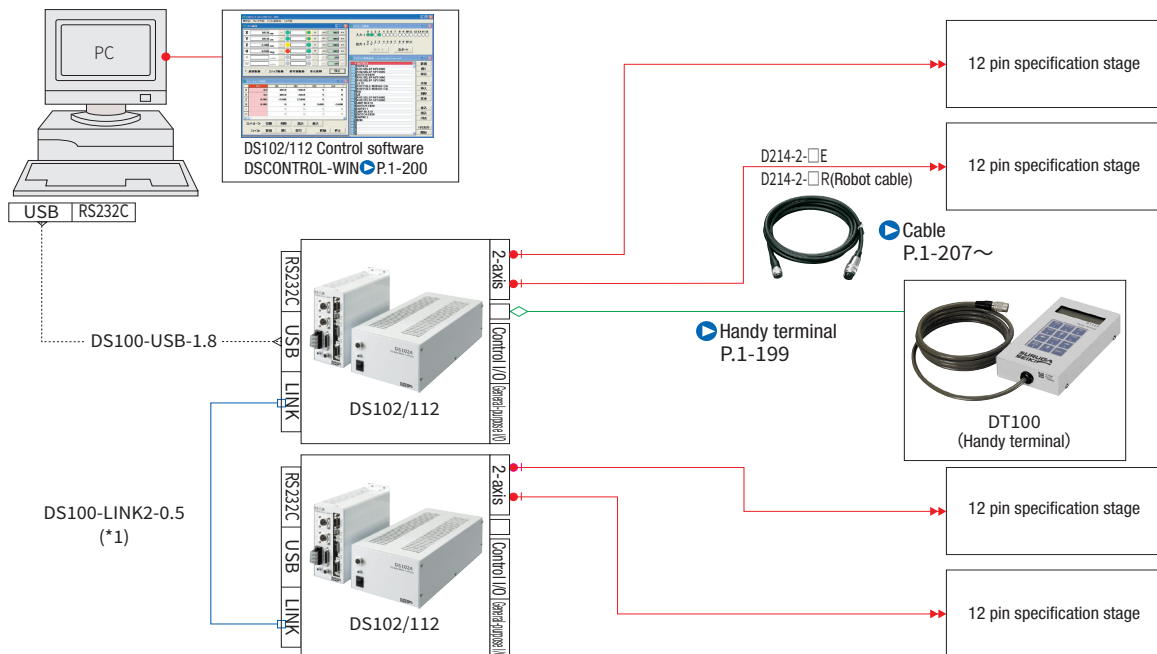

(*1) It is possible to control up to 3 controllers (for a maximum of 6-axis control) with link function.

■ Connection example 3 When controlling from the PLC I/O Unit.

*USB cable connection between PC and controller.

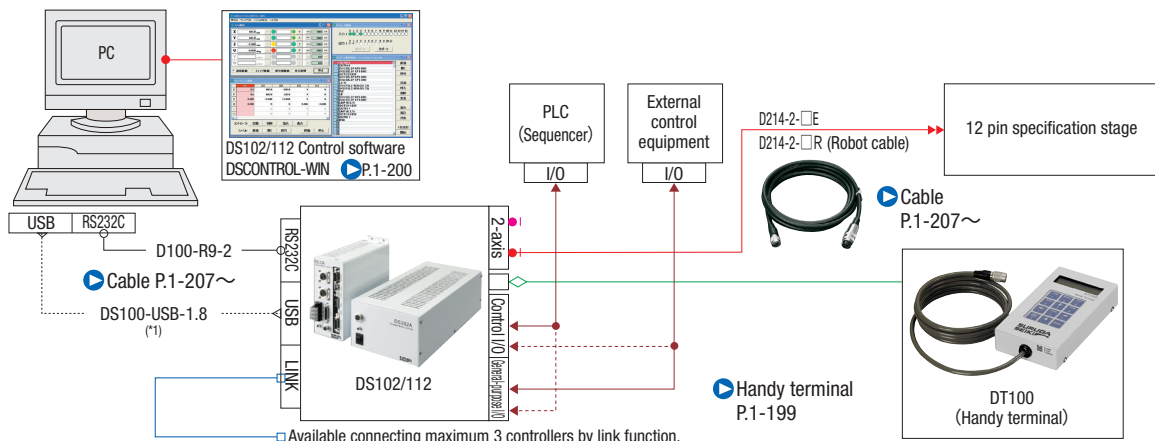

(*1) Using the USB hub, it is controllable in a single PC up to four link networks (24-axis).

Goniometer Stage □40 : KGW04 (1-Axis)

1-axis
KGW04040T-LC

KGW04040M-LC

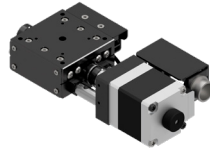
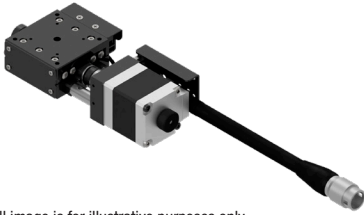

All image is for illustrative purposes only.

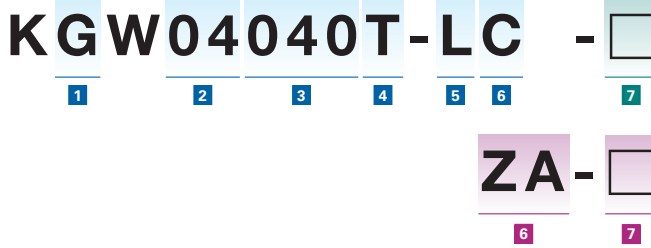

Calbes P.1-287~
Electrical specification P.1-201~

1 Axis

G	1-axis
---	--------

2 Table size

04	□40mm
----	-------

3 Height of center rotation (W.D.)

040	40mm
060	60mm

4 Connector specifications

T	Pigtail	
M	Panel Mount	

5 Sensor cover location specification

L	L position	
R	Opposite hand	

6 Motor option

Code	Specification
C	Standard
G	High resolution

6 Motor option

Code	Specification
PA	αSTEP (AR Series)
ZA	αSTEP (AZ Series)
EA	Motor for EtherCAT
UG	Servo motor(MINAS A6)
UA	Servo motor(J4)

7 Cable option (Motor: C·G)

Code	Specification	Cable type
Blank	Cable is not included (Standard)	—
A	2m	D214-2-2E
B	2m One end loose	D214-2-2EK
C	4m	D214-2-4E
D	4m One end loose	D214-2-4EK
E	Only connector (Cable is not included)	—
F	Robot cable 2m	D214-2-2R
G	Robot cable 2m one end loose	D214-2-2RK
H	Robot cable 4m	D214-2-4R
J	Robot cable 4m one end loose	D214-2-4RK

7 Cable option (Motor: PA·ZA·EA·UG·UA)

Code	Specification
Blank	Sensor cable 2m One end loose wire
3	Sensor cable 3m One end loose wire
5	Sensor cable 5m One end loose wire
3A	Driver (Amplifier)/Cable set 3m
5A	Driver (Amplifier)/Cable set 5m

Driver (Amplifier) · Cable option

Code	*Combination	Blank			3A		5A	
		PA/ZA/EA/UG/UA	3	5	PA/ZA	EA/UG/UA	PA/ZA	EA/UG/UA
Cable	Sensor	2m	3m	5m	3m		5m	
	Motor	Not included			3m		5m	5m
	Encoder	Not included			—	3m	—	5m
Driver (Amplifier)		Not included			Included			

*Motor driver (amplifier)/cable combination

Selection Example



Motorized
goniometer Stage

X

XY

Z

Horizontal
Z

XYZ

Goniometer

Rotary

Unit

Controller

Ball
Screw

Worm
Gear

□40

□50

□60

□70

Specification

SPEC				
Model	KGW04040T-LC	KGW04060T-LC	KGW04040M-LC	KGW04060M-LC
Opposite hand	KGW04040T-RC	KGW04060T-RC	KGW04040M-RC	KGW04060M-RC
Mechanical specification	Travel distance	±8°	±6°	±8°
	Stage surface size	40×40mm		
	Connector type	Pigtail		Panel Mount
	Travel mechanism (Reduction ratio)	Worm gear(1/240)		
	Guide	Cross Roller Guide		
	Main materials-Finishing	Aluminum - Black alumite finishing,Phosphor bronze - Black paint		
	Weight	0.39kg		0.38kg
Dimensional specification	Height of stage	20±0.2mm		
	Height of center rotation	40±0.2mm	60±0.2mm	40±0.2mm
	Runout accuracy of center rotation	0.01mm以内		
Accuracy specification	Resolution/Pulse	0.003°(Full)		
	MAX speed	15°/sec[5kHz]		
	Repeatability positioning accuracy	±0.005°		
	Load capacity	3kgf [29.4N]		
	Moment stiffness	Pitch 1.30/Yaw 1.16/Roll 0.27["/N · cm]		
	Lost motion	0.01°		
Sensor	Limit sensor	Available		
	Origin sensor	Available		
	Slit origin sensor	-		
Provided screw (Hexagon-headed bolt)	4 of M3 - 6			

* Might be changed specification due to motors.

X
XY
Z
Horizontal
Z
XYZ

Goniometer

Rotary

Unit

Controller

Resolution · MAX speed · Weight

Motor code	C	G
Type	Standard	High resolution
Motor model*3	C005C-90215P-1	PK523HPMB-C1
Step angle	0.72°	0.36°
Resolution	0.003°	0.0015°
MAX speed	15°/sec	
Weight	KGW04-T (Pigtail)	0.39kg
	KGW04-M (Panel Mount)	0.38kg

Motor code	PA	ZA	EA	UG	UA
Type	αSTEP (AR Series)	αSTEP (AZ Series)	Motor for EtherCAT	MINAS A6	J4
Motor model*3	ARM24SAK	AZM24AK	STM28W100A	MSMF5AZL1A2	HG-KR053
Resolution	0.0015°(1000P/R setting)			23 Bit encoder (8388608P/R)*1	22 Bit encoder (4194304P/R)*2
MAX speed	30°/sec			45°/sec	
Weight	KGW04-T (Pigtail)	0.43kg	0.40kg	0.64kg	0.66kg
	KGW04-M (Panel Mount)	0.42kg	0.39kg	0.63kg	0.65kg

*1 Optional encoder cable is for incremental system.

*2 When constructing an absolute system, it is necessary to install a battery in the amplifier.

*3 Model numbers include Suruga Seiki's proprietary management codes.

Ball
Screw

Worm
Gear

40

50

60

70

Goniometer Stage □40 : KGW04 (1-Axis)

Dimensions

KGW04-L Seires

Top view :KGW04□□□T-LC (Pigtail)

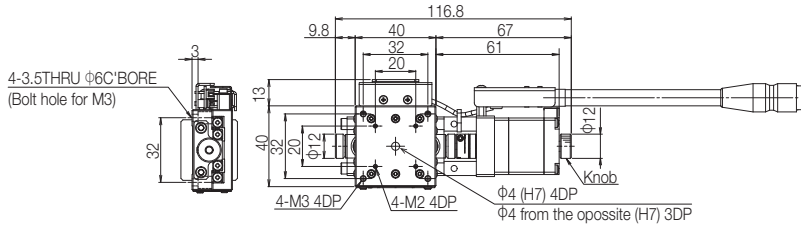

Side view :common

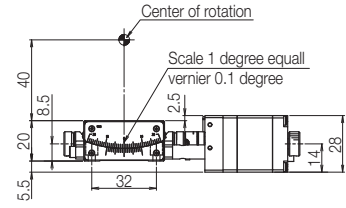

KGW04040T(M)-LC

上面図 : KGW04□□□M-LC (パネルマウント仕様)

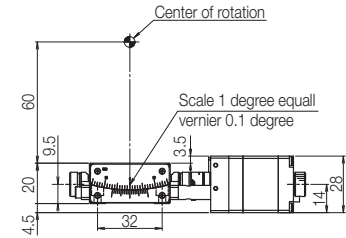
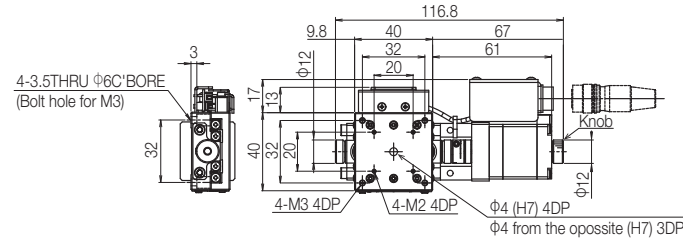

KGW04060T(M)-LC

KGW04-R Seires

Side view :common

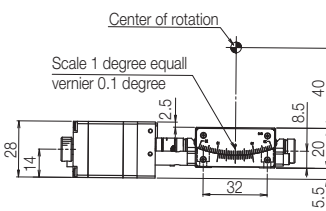

Top view :KGW04□□□T-RC (Pigtail)

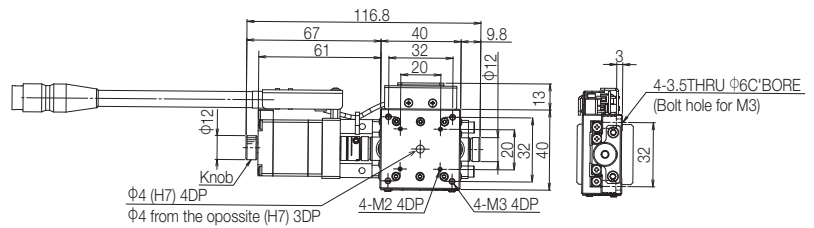

KGW04040T(M)-RC

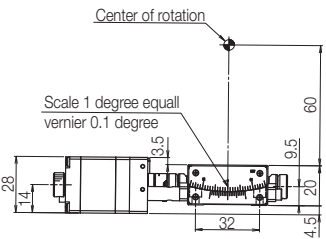

上面図 : KGW04□□□M-RC (パネルマウント仕様)

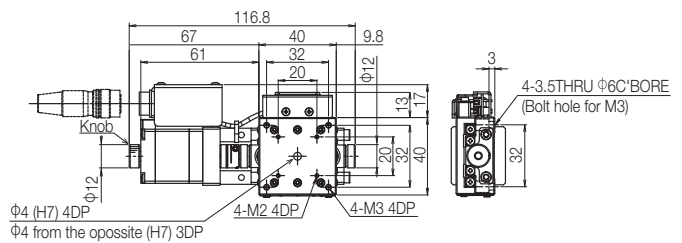

KGW04060T(M)-RC

Motorized
goniometer Stage

X

XY

Z

Horizontal

Z

XYZ

Goniometer

Rotary

Unit

Controller

Ball
Screw

Worm
Gear

□40

□50

□60

□70

Dimensions

Side view

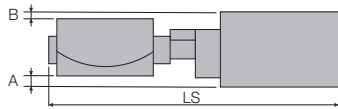

Top view :Connector :T(Pigtail)

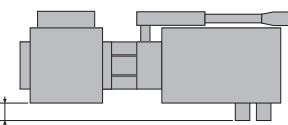

Top view :Connector :M(Panel Mount)

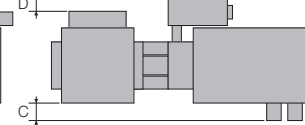

C Standard motor

G High resolution

Motor Model C005C-90215P-1

Motor Model PK523HPMB-C1

Model	Motor code	Motor size	Connector type	A(mm)	B(mm)	C(mm)	D(mm)	LS(mm)
KGW04040T-□□	C · G	□28	T	5.5	2.5	—	—	116.8
KGW04060T-□□				4.5	3.5			
KGW04040M-□□			M	5.5	2.5		4	
KGW04060M-□□				4.5	3.5			

EA Motor for EtherCAT

Motor Model STM28W100A

Model	Motor code	Motor size	Connector type	A(mm)	B(mm)	C(mm)	D(mm)	LS(mm)
KGW04040T-L(R)EA	EA	□28	T	5.5	2.5	—	—	145.1
KGW04060T-L(R)EA				4.5	3.5			
KGW04040M-L(R)EA			M	5.5	2.5			
KGW04060M-L(R)EA				4.5	3.5			

PA αSTEP (AR Series)

Motor Model ARM24SAK

ZA αSTEP (AZ Series)

Motor Model AZM24AK

Model	Motor code	Motor size	Connector type	A(mm)	B(mm)	C(mm)	D(mm)	LS(mm)
KGW04040T-L(R)PA	PA	□28	T	5.5	2.5	—	—	129.8
KGW04060T-L(R)PA				4.5	3.5			
KGW04040M-L(R)PA			M	5.5	2.5			
KGW04060M-L(R)PA				4.5	3.5			
KGW04040T-L(R)ZA	ZA	□28	T	5.5	2.5	—	—	139.3
KGW04060T-L(R)ZA				4.5	3.5			
KGW04040M-L(R)ZA			M	5.5	2.5			
KGW04060M-L(R)ZA				4.5	3.5			

UG Servo motor MINAS A6 (Panasonic)

Motor Model MSMF5AZL1A2

UA Servo motor J4 (Mitsubishi Electric corporation)

Motor Model HG-KR053

Model	Motor code	Motor size	Connector type	A(mm)	B(mm)	C(mm)	D(mm)	LS(mm)
KGW04040T-L(R)UG	UG	□38	T	10.5	7.5	12	—	169.8
KGW04060T-L(R)UG				9.5	8.5			
KGW04040M-L(R)UG			M	10.5	7.5		4	
KGW04060M-L(R)UG				9.5	8.5			
KGW04040T-L(R)UA	UA	□40	T	11.8	8.8	8.8	—	164.2
KGW04060T-L(R)UA				10.8	9.8			
KGW04040M-L(R)UA			M	11.8	8.8		4	
KGW04060M-L(R)UA				10.8	9.8			

Motorized
goniometer Stage

X

XY

Z

Horizontal
Z

XYZ

Goniometer

Rotary

Unit

Controller

Ball
Screw

Worm
Gear

□40

□50

□60

□70

1

208

Motorized Stage

Goniometer Stage □40: KAW04 (2-axis)

■ 2-Axis
KAW04040T-LC

KAW04040M-LC



All image is for illustrative purposes only.

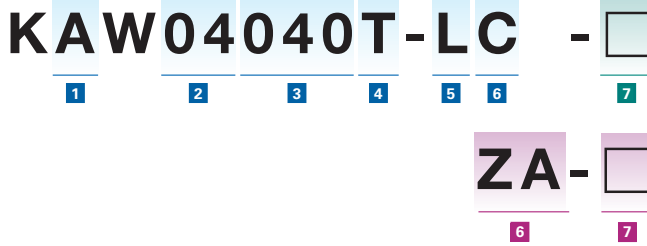

▶ Calbes P.1-287~
▶ Electrical specification P.1-201~

1 Axis

A	2-Axis
---	--------

2 Table size

04	□40mm
----	-------

3 Height of center rotation (W.D.)

040	40mm
-----	------

4 Connector specifications

T	Pigtail	
M	Panel Mount	

5 Sensor cover location specification

L	L position
R	Opposite hand

6 Motor option

Code	Specification
C	Standard
G	High resolution

6 Motor option

Code	Specification
PA	αSTEP (AR Series)
ZA	αSTEP (AZ Series)
EA	Motor for EtherCAT
UG	Servo motor(MINAS A6)
UA	Servo motor(J4)

7 Cable option (Motor: C · G)

Code	Specification	Cable type
Blank	Cable is not included (Standard)	—
A	2m	D214-2-2E
B	2m One end loose	D214-2-2EK
C	4m	D214-2-4E
D	4m One end loose	D214-2-4EK
E	Only connector (Cable is not included)	—
F	Robot cable 2m	D214-2-2R
G	Robot cable 2m one end loose	D214-2-2RK
H	Robot cable 4m	D214-2-4R
J	Robot cable 4m one end loose	D214-2-4RK

7 Cable option (Motor: PA · ZA · EA · UG · UA)

Code	Specification
Blank	Sensor cable 2m One end loose wire
3	Sensor cable 3m One end loose wire
5	Sensor cable 5m One end loose wire
3A	Driver (Amplifier)/Cable set 3m
5A	Driver (Amplifier)/Cable set 5m

Driver (Amplifier) · Cable option

Code	*Combination Motor	Blank	3			5A	
			PA/ZA/EA/UG/UA	5	PA/ZA	EA/UG/UA	PA/ZA
Cable	Sensor	2m	3m	5m	3m		5m
	Motor	Not included			3m		5m
	Encoder	Not included			—	3m	—
Driver (Amplifier)	Not included			Included			

*Motor driver (amplifier)/cable combination

Selection Example



Motorized
goniometer Stage

- X
- XY
- Z
- Horizontal Z
- XYZ
- Goniometer

- Rotary
- Unit
- Controller

Ball Screw

Worm Gear

□40

□50

□60

□70

Specification

SPEC			
Model	KAW04040T-LC	KAW04040M-LC	
Opposite hand	KAW04040T-RC	KAW04040M-RC	
Mechanical specification	Travel distance Upper/Lower	±8°/±6°	
	Stage surface size	40×40mm	
	Connector type	Pigtail	Panel Mount
	Travel mechanism (Reduction ratio)	Worm gear(1/240)	
	Guide	Cross Roller Guide	
	Main materials-Finishing	Aluminum - Black alumite finishing,Phosphor bronze - Black paint	
	Weight	0.78kg	0.76kg
Dimension	Height of stage	40±0.4mm	
	Height of center rotation	40±0.4mm	
	Runout accuracy of center rotation	-	
Accuracy specification	Resolution/Pulse	0.003°(Full)	
	MAX speed	Upper	15°/sec[5kHz]
		Lower	15°/sec[5kHz]
	Repeatability positioning accuracy	±0.005°	
	Load capacity	2.5kgf [24.5N]	
Moment stiffness	Pitch 1.57/Yaw 2.32/Roll 1.57["/N · cm]		
Sensor	Lost motion	0.01°	
	Limit sensor	Available	
	Origin sensor	Available	
	Slit origin sensor	-	
Provided screw (Hexagon-headed bolt)	4 of M3 - 6		

* Might be changed specification due to motors.

X

XY

Z

Horizontal

Z

XYZ

Goniometer

Rotary

Unit

Controller

Ball
Screw

Worm
Gear

Resolution · MAX speed · Weight

Motor code	C		G	
Type	Standard		High resolution	
Motor model*3	C005C-90215P-1		PK523HPMB-C1	
Step angle	0.72°		0.36°	
Resolution(Full)	Upper	0.003°	0.0015°	
	Lower			
MAX speed	Upper	15°/sec		
	Lower			
Weight	KAW04-T (Pigtail)	0.78kg		
	KAW04-M (Panel Mount)	0.76kg		

Motor code	PA	ZA	EA	UG	UA
Type	αSTEP (AR Series)	αSTEP (AZ Series)	Motor for EtherCAT	MINAS A6	J4
Motor model*3	ARM24SAK	AZM24AK	STM28W100A	MSMF5AZL1A2	HG-KR053
Resolution	Upper	0.0015° (1000P/R setting)			23 Bit encoder (8388608P/R)*1
	Lower				
MAX speed	Upper	30°/sec			45°/sec
	Lower				
Weight	KAW04-T (Pigtail)	0.86kg	0.80kg	1.28kg	1.32kg
	KAW04-M (Panel Mount)	0.84kg	0.78kg	1.26kg	1.30kg

*1 Optional encoder cable is for incremental system.

*2 When constructing an absolute system, it is necessary to install a battery in the amplifier.

*3 Model numbers include Suruga Seiki's proprietary management codes.

40

50

60

70

Motorized Stage

Goniometer Stage □40: KAW04 (2-Axis)

Dimensions

KAW04-L Series

Top view :KAW04040T-LC (Pigtail)

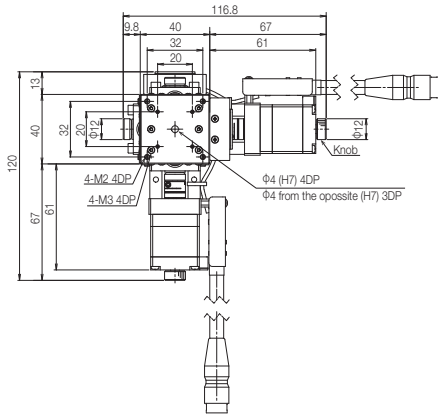

Side view :common

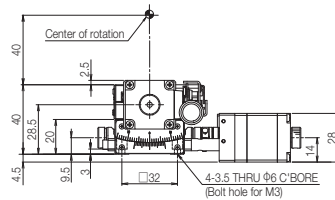

KAW04040T(M)-LC

Top view :KAW04040M-LC (Panel Mount)

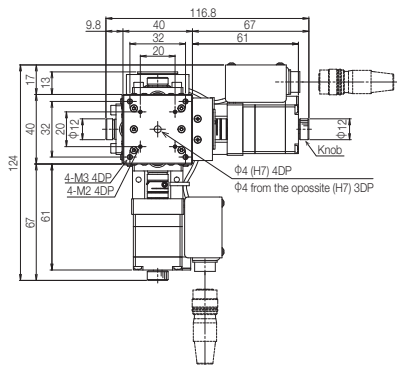

KAW04-R Series

Side view :common

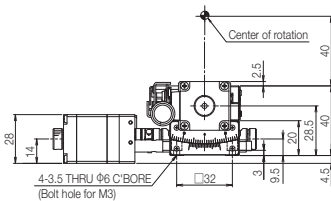

KAW04040T(M)-RC

Top view :KAW04040T-RC (Pigtail)

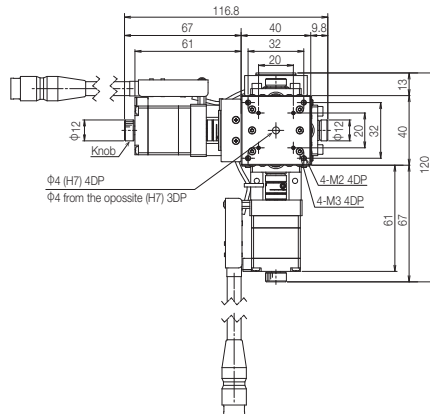

Top view :KAW04040M-RC (Panel Mount)

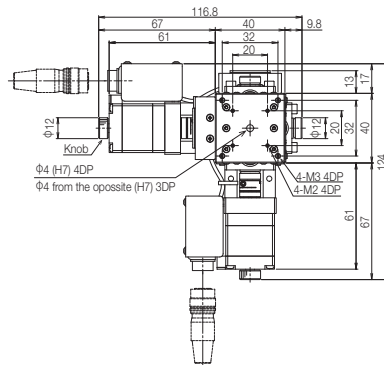

Motorized
goniometer Stage

X

XY

Z

Horizontal
Z

XYZ

Goniometer

Rotary

Unit

Controller

Ball
Screw

Worm
Gear

□40

□50

□60

□70

Dimensions

Side view

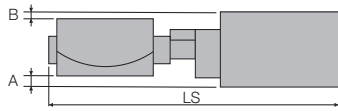

Top view :Connector :T(Pigtail)

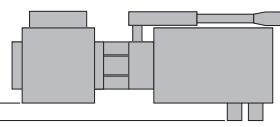

Top view :Connector :M(Panel Mount)

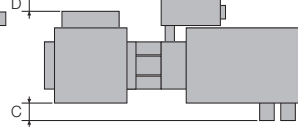

C Standard motor

Motor Model C005C-90215P-1

G High resolution

Motor Model PK523HPMB-C1

Model	Motor code	Motor size	Connector type	A(mm)	B(mm)	C(mm)	D(mm)	LS(mm)
KGW04040T-□□	C · G	□28	T	5.5	2.5	—	—	116.8
KGW04060T-□□				4.5	3.5			
KGW04040M-□□			M	5.5	2.5			
KGW04060M-□□				4.5	3.5			

EA Motor for EtherCAT

Motor Model STM28W100A

Model	Motor code	Motor size	Connector type	A(mm)	B(mm)	C(mm)	D(mm)	LS(mm)
KGW04040T-L(R)EA	EA	□28	T	5.5	2.5	—	—	145.1
KGW04060T-L(R)EA				4.5	3.5			
KGW04040M-L(R)EA			M	5.5	2.5			
KGW04060M-L(R)EA				4.5	3.5			

PA αSTEP (AR Series)

Motor Model ARM24SAK

ZA αSTEP (AZ Series)

Motor Model AZM24AK

Model	Motor code	Motor size	Connector type	A(mm)	B(mm)	C(mm)	D(mm)	LS(mm)
KGW04040T-L(R)PA	PA	□28	T	5.5	2.5	—	—	129.8
KGW04060T-L(R)PA				4.5	3.5			
KGW04040M-L(R)PA			M	5.5	2.5			
KGW04060M-L(R)PA				4.5	3.5			
KGW04040T-L(R)ZA	ZA	□28	T	5.5	2.5	—	—	139.3
KGW04060T-L(R)ZA				4.5	3.5			
KGW04040M-L(R)ZA			M	5.5	2.5			
KGW04060M-L(R)ZA				4.5	3.5			

UG Servo motor MINAS A6 (Panasonic)

Motor Model MSMF5AZL1A2

UA Servo motor J4 (Mitsubishi Electric corporation)

Motor Model HG-KR053

Model	Motor code	Motor size	Connector type	A(mm)	B(mm)	C(mm)	D(mm)	LS(mm)
KGW04040T-L(R)UG	UG	□38	T	10.5	7.5	12	—	169.8
KGW04060T-L(R)UG				9.5	8.5			
KGW04040M-L(R)UG			M	10.5	7.5			
KGW04060M-L(R)UG				9.5	8.5			
KGW04040T-L(R)UA	UA	□40	T	11.8	8.8	8.8	—	164.2
KGW04060T-L(R)UA				10.8	9.8			
KGW04040M-L(R)UA			M	11.8	8.8			
KGW04060M-L(R)UA				10.8	9.8			

Motorized
goniometer Stage

X

XY

Z

Horizontal
Z

XYZ

Goniometer

Rotary

Unit

Controller

Ball
Screw

Worm
Gear

□40

□50

□60

□70

1

212

Goniometer Stage □60 : KGW06 (1-Axis)

1-Axis
KGW06050T-LC

KGW06050M-LC



* All image is for illustrative purposes only.

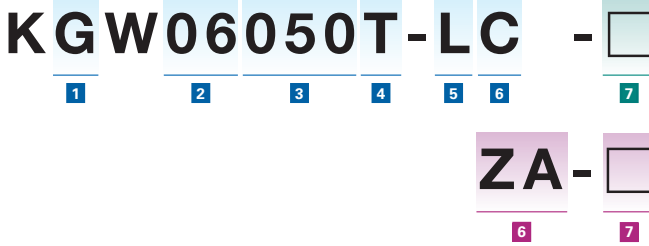

Calbes P.1-287~
Electrical specification P.1-201~

1 Axis

G	1-axis
---	--------

2 Table size

06	□60mm
----	-------

3 Height of center rotation (W.D.)

050	50 mm
075	75 mm
100	100 mm
125	125 mm

4 Connector specifications

T	Pigtail	
M	Panel Mount	

5 Sensor cover location specification

L	L position	
R	Opposite hand	

6 Motor option

Code	Specification
C	Standard
G	High resolution

6 Motor option

Code	Specification
PA	αSTEP (AR Series)
ZA	αSTEP (AZ Series)
EA	Motor for EtherCAT
UG	Servo motor(MINAS A6)
UA	Servo motor(J4)

7 Cable option (Motor: C · G)

Code	Specification	Cable type
Blank	Cable is not included (Standard)	—
A	2m	D214-2-2E
B	2m One end loose	D214-2-2EK
C	4m	D214-2-4E
D	4m One end loose	D214-2-4EK
E	Only connector (Cable is not included)	—
F	Robot cable 2m	D214-2-2R
G	Robot cable 2m one end loose	D214-2-2RK
H	Robot cable 4m	D214-2-4R
J	Robot cable 4m one end loose	D214-2-4RK

7 Cable option (Motor: PA · ZA · EA · UG · UA)

Code	Specification
Blank	Sensor cable 2m One end loose wire
3	Sensor cable 3m One end loose wire
5	Sensor cable 5m One end loose wire
3A	Driver (Amplifier)/Cable set 3m
5A	Driver (Amplifier)/Cable set 5m

Driver (Amplifier) · Cable option

Code	*Combination Motor	Blank			3		5		3A		5A	
		PA/ZA/EA/UG/UA	3	5	PA/ZA	EA/UG/UA	PA/ZA	EA/UG/UA				
Cable	Sensor	2m	3m	5m	3m		5m					
	Motor	Not included					3m		5m			
	Encoder						—	3m	—	5m		
Driver (Amplifier)		Not included					Included					

* Motor driver (amplifier)/cable combination

Selection Example



Motorized
goniometer Stage

X

XY

Z

Horizontal
Z

XYZ

Goniometer

Rotary

Unit

Controller

Ball
Screw

Worm
Gear

□40

□50

□60

□70

Specification

		SPEC							
Model	KGW06050T-LC	KGW06075T-LC	KGW06100T-LC	KGW06125T-LC	KGW06050M-LC	KGW06075M-LC	KGW06100M-LC	KGW06125M-LC	
Opposite hand	KGW06050T-RC	KGW06075T-RC	KGW06100T-RC	KGW06125T-RC	KGW06050M-RC	KGW06075M-RC	KGW06100M-RC	KGW06125M-RC	
Mechanical specification	Travel distance	±10°	±8°	±6°	±5°	±10°	±8°	±6°	±5°
	Stage surface size	60×60mm				60×60mm			
	Connector type	Pigtail				Panel Mount			
	Travel mechanism (Reduction ratio)	Worm gear(1/160)	Worm gear(1/225)	Worm gear(1/292)	Worm gear(1/360)	Worm gear(1/160)	Worm gear(1/225)	Worm gear(1/292)	Worm gear(1/360)
	Guide	Cross Roller Guide				Cross Roller Guide			
Main materials-Finishing	Aluminum - Black alumite finishing				Aluminum - Black alumite finishing				
	Weight	0.51kg				0.5kg			
Dimensional accuracy	Height of stage	25±0.2mm				25±0.2mm			
	Height of center rotation	50±0.2mm	75±0.2mm	100±0.2mm	125±0.2mm	50±0.2mm	75±0.2mm	100±0.2mm	125±0.2mm
	Runout accuracy of center rotation	0.01mm以内				0.01mm以内			
Accuracy specification	Resolution/Pulse	0.0045°(Full)	0.0032°(Full)	0.002466°(Full)	0.002°(Full)	0.0045°(Full)	0.0032°(Full)	0.002466°(Full)	0.002°(Full)
	MAX speed	22.5°/sec[5kHz]	16°/sec[5kHz]	12.5°/sec[5kHz]	10°/sec[5kHz]	22.5°/sec[5kHz]	16°/sec[5kHz]	12.5°/sec[5kHz]	10°/sec[5kHz]
	Repeatability positioning accuracy	±0.003°				±0.003°			
	Load capacity	5kgf[49N]				5kgf[49N]			
	Moment stiffness	Pitch 0.30/Yaw 0.10/Roll 0.11[°/N · cm]				Pitch 0.30/Yaw 0.10/Roll 0.11[°/N · cm]			
Sensor	Lost motion	0.01°以内				0.01°以内			
	Limit sensor	Available				Available			
	Origin sensor	Available				Available			
	Slit origin sensor	-				-			
Provided screw (Hexagon-headed bolt)	4 of M4 - 10				4 of M4 - 10				

* Might be changed specification due to motors.

Resolution · MAX speed · Weight

Motor code	C		G	
Type	Standard		High resolution	
Motor model*3	C005C-90215P-1		PK523HPMB-C1	
Step angle	0.72°		0.36°	
Resolution (Full)	KGW06050	0.0045°	0.00225°	
	KGW06075	0.0032°	0.0016°	
	KGW06100	0.002466°	0.001233°	
	KGW06125	0.002°	0.001°	
MAX speed	KGW06050	22.5°/sec		
	KGW06075	16°/sec		
	KGW06100	12.5°/sec		
	KGW06125	10°/sec		
Weight	KGW06-T (Pigtail)	0.51kg		
	KGW06-M (Panel Mount)	0.50kg		

Motor code	PA	ZA	EA	UG	UA
Type	αSTEP (AR Series)	αSTEP (AZ Series)	Motor for EtherCAT	MINAS A6	J4
Motor model*3	ARM24SAK	AZM24AK	STM28W100A	MSMF5AZL1A2	HG-KR053
Resolution (Full)	KGW06050	0.00225° (1000P/R setting)		23 Bit encoder (8388608P/R)*1	22 Bit encoder (4194304P/R)*2
	KGW06075	0.0016°(1000P/R setting)			
	KGW06100	0.001233°(1000P/R setting)			
	KGW06125	0.001° (1000P/R setting)			
MAX speed	KGW06050	45°/sec		67.5°/sec	
	KGW06075	32°/sec		48°/sec	
	KGW06100	25°/sec		37.5°/sec	
	KGW06125	20°/sec		30°/sec	
Weight	KGW06-T (Pigtail)	0.55kg	0.52kg	0.76kg	0.78kg
	KGW06-M (Panel Mount)	0.54kg	0.51kg	0.75kg	0.77kg

*1 Optional encoder cable is for incremental system.

*2 When constructing an absolute system, it is necessary to install a battery in the amplifier.

*3 Model numbers include Suruga Seiki's proprietary management codes.

- X
- XY
- Z
- Horizontal Z
- XYZ
- Goniometer
- Rotary
- Unit
- Controller

Ball Screw

Worm Gear

□40

□50

□60

□70

Goniometer Stage □60 : KGW06

Dimensions

KGW06-L Seires

Top view :KGW06□□□T-LC (Pigtail)

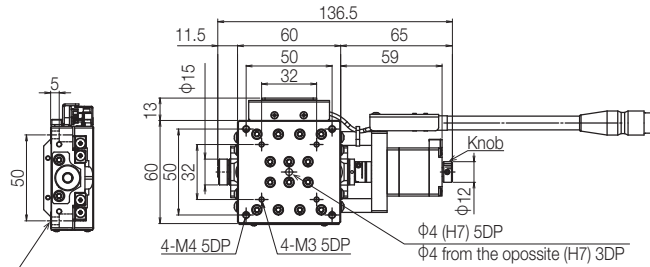

4-4.5 THRU Φ8 C'BORE
(Bolt hole for M4)

Side view :common

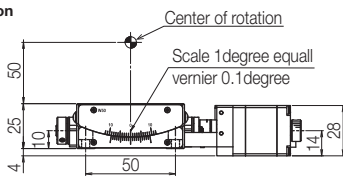

KGW06050T (M) -LC

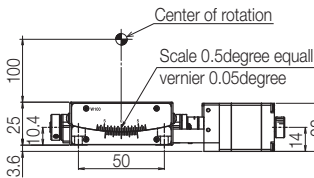

KGW06100T (M) -LC

Top view :KGW06□□□M-LC (Panel Mount)

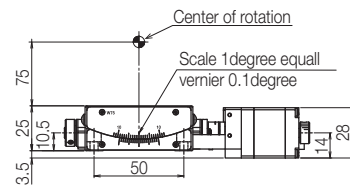
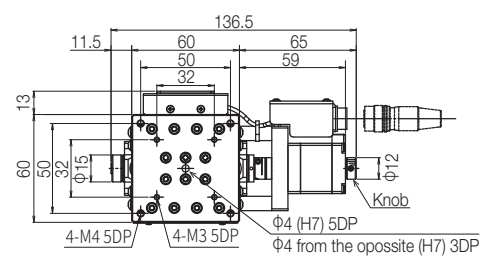

KGW06075T (M) -LC

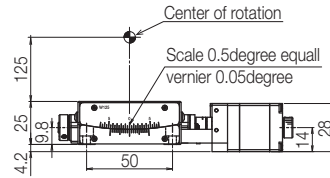

KGW06125T (M) -LC

KGW06-R Series

Top view :KGW06□□□M-RC (Panel Mount)

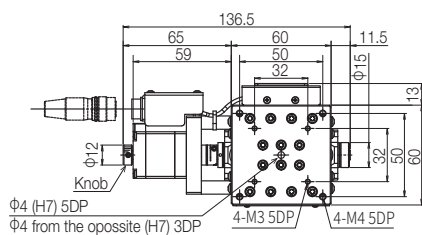

Side view :common

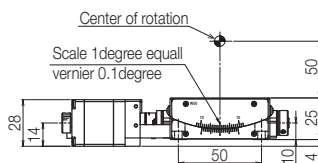

KGW06050T (M) -RC

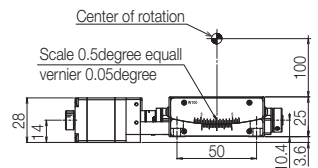

KGW06100T (M) -RC

Top view :KGW06□□□T-RC (Pigtail)

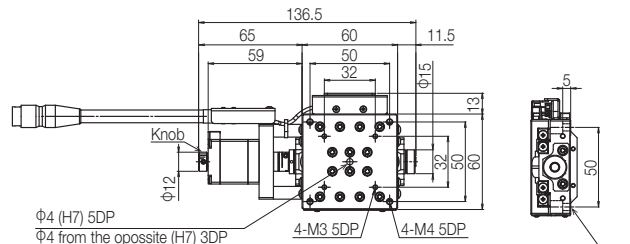

4-4.5 THRU Φ8 C'BORE
(Bolt hole for M4)

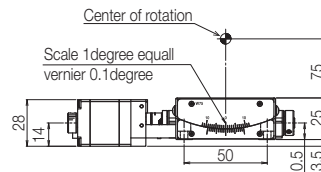

KGW06075T (M) -RC

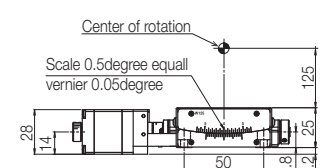

KGW06125T (M) -RC

Dimensions

C Standard motor

Motor Model C005C-90215P-1

G High resolution

Motor Model PK523HPMB-C1

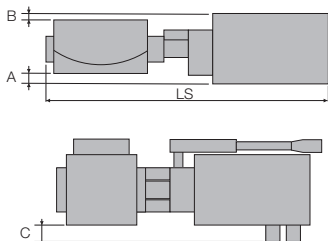

Model	Motor code	Motor size	Connector type	A(mm)	B(mm)	C(mm)	LS(mm)
KGW06050□-□□	C・G	□28	T・M	4.1	-	-	136.5
KGW06075□-□□				3.5			
KGW06100□-□□				3.7			
KGW06125□-□□				4.2			

EA Motor for EtherCAT

Motor Model STM28W100A

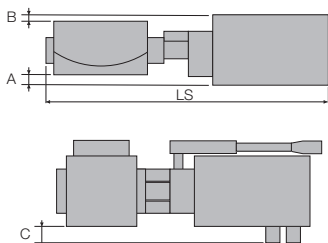

Model	Motor code	Motor size	Connector type	A(mm)	B(mm)	C(mm)	LS(mm)
KGW06050□-□EA	EA	□28	T・M	4.1	-	-	162.8
KGW06075□-□EA				3.5			
KGW06100□-□EA				3.7			
KGW06125□-□EA				4.2			

PA αSTEP (AR Series)

Motor Model ARM24SAK

ZA αSTEP (AZ Series)

Motor Model AZM24AK

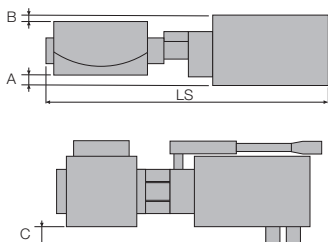

Model	Motor code	Motor size	Connector type	A(mm)	B(mm)	C(mm)	LS(mm)
KGW06050□-□PA	AR	□28	T・M	4.1	-	-	147.5
KGW06075□-□PA				3.5			
KGW06100□-□PA				3.7			
KGW06125□-□PA				4.2			
KGW06050□-□ZA	ZA	□28	T・M	4.1	-	-	157
KGW06075□-□ZA				3.5			
KGW06100□-□ZA				3.7			
KGW06125□-□ZA				4.2			

UG Servo motor MINAS A6 (Panasonic)

Motor Model MSMF5AZL1A2

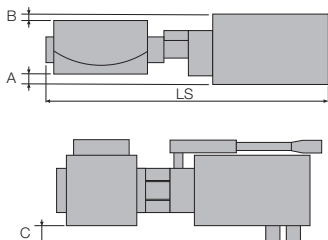

UA Servo motor J4 (Mitsubishi Electric corporation)

Motor Model HG-KR053

Model	Motor code	Motor size	Connector type	A(mm)	B(mm)	C(mm)	LS(mm)
KGW06050□-□UG	UG	□38	T・M	9.1	4	2	187.5
KGW06075□-□UG				8.5	4.5		
KGW06100□-□UG				8.7	4.4		
KGW06125□-□UG				9.2	3.8		
KGW06050□-□UA	UA	□40	T・M	10.4	5.3	-	181.9
KGW06075□-□UA				9.8	5.8		
KGW06100□-□UA				10	5.7		
KGW06125□-□UA				10.5	5.1		

X

XY

Z

Horizontal

Z

XYZ

Goniometer

Rotary

Unit

Controller

Ball
Screw

Worm
Gear

□40

□50

□60

□70

Specification

SPEC								
Model		KAW06050T-LC	KAW06075T-LC	KAW06100T-LC	KAW06050M-LC	KAW06075M-LC	KAW06100M-LC	
Opposite hand		KAW06050T-RC	KAW06075T-RC	KAW06100T-RC	KAW06050M-RC	KAW06075M-RC	KAW06100M-RC	
Mechanical specification	Travel distance Upper/Lower	±10°/±8°			±8°/±6°			±6°/±5°
	Stage surface size	60×60mm			60×60mm			
	Connector type	Pigtail			Panel Mount			
	Travel mechanism (Reduction ratio)	Upper	Worm gear(1/160)	Worm gear(1/225)	Worm gear(1/292)	Worm gear(1/160)	Worm gear(1/225)	Worm gear(1/292)
		Lower	Worm gear(1/225)	Worm gear(1/292)	Worm gear(1/360)	Worm gear(1/225)	Worm gear(1/292)	Worm gear(1/360)
	Guide	Cross Roller Guide			Cross Roller Guide			
	Main materials-Finishing	Aluminum - Black alumite finishing			Aluminum - Black alumite finishing			
Weight	1.02kg			1.00kg				
Dimensional tolerance	Height of stage	50±0.4mm			50±0.4mm			
	Height of center rotation	50±0.4mm	75±0.4mm	100±0.4mm	50±0.4mm	75±0.4mm	100±0.4mm	
	Runout accuracy of center rotation	—			—			
Accuracy specification	Resolution/Pulse	Upper	0.0045°(Full)	0.0032°(Full)	0.002466°(Full)	0.0045°(Full)	0.0032°(Full)	0.002466°(Full)
		Lower	0.0032°(Full)	0.002466°(Full)	0.002°(Full)	0.0032°(Full)	0.002466°(Full)	0.002°(Full)
	MAX speed	Upper	22.5°/sec[5kHz]	16°/sec[5kHz]	12.5°/sec[5kHz]	22.5°/sec[5kHz]	16°/sec[5kHz]	12.5°/sec[5kHz]
		Lower	16°/sec[5kHz]	12.5°/sec[5kHz]	10°/sec[5kHz]	16°/sec[5kHz]	12.5°/sec[5kHz]	10°/sec[5kHz]
	Repeatability positioning accuracy	±0.003°以内			±0.003°以内			
	Load capacity	4.5kgf【44.1N】			4.5kgf【44.1N】			
Moment stiffness	Pitch 0.41/Yaw 0.20/Roll 0.41["/N · cm]			Pitch 0.41/Yaw 0.20/Roll 0.41["/N · cm]				
Sensor	Limit sensor	Available			Available			
	Origin sensor	Available			Available			
	Slit origin sensor	—			—			
	Provided screw (Hexagon-headed bolt)	4 of M4 - 10			4 of M4 - 10			

* Might be changed specification due to motors.

Resolution · MAX speed · Weight

Motor code		C	G
Type		Standard	High resolution
Motor model*3		C005C-90215P-1	PK523HPMB-C1
Step angle		0.72°	0.36°
Resolution (Upper/Lower)	KAW06050	0.0045° 0.0032°	0.00225° 0.0016°
	KAW06075	0.0032° 0.002466°	0.0016° 0.001233°
	KAW06100	0.002466° 0.002°	0.001233° 0.001°
MAX speed (Upper/Lower)	KAW06050	22.5°/sec 16°/sec	
	KAW06075	16°/sec 12.5°/sec	
	KAW06100	12.5°/sec 10°/sec	
Weight	KAW06-T (Pigtail)	1.02kg	
	KAW06-M (Panel Mount)	1.00kg	

Motor code		PA	ZA	EA	UG	UA
Type		αSTEP (AR Series)	αSTEP (AZ Series)	Motor for EtherCAT	MINAS A6	J4
Motor model*3		ARM24SAK	AZM24AK	STM28W100A	MSMF5AZL1A2	HG-KR053
Resolution (Upper/Lower)	KAW06050	0.00225° 0.0016°(1000P/R setting)			23 Bit encoder (8388608P/R)*1	22 Bit encoder (4194304P/R)*2
	KAW06075	0.0016° 0.001233° (1000P/R setting)				
	KAW06100	0.001233° 0.001° (1000P/R setting)				
MAX speed (Upper/Lower)	KAW06050	45°/sec 32°/sec			67.5°/sec 48°/sec	
	KAW06075	32°/sec 25°/sec			48°/sec 37.5°/sec	
	KAW06100	25°/sec 20°/sec			37.5°/sec 30°/sec	
Weight	KAW06-T (Pigtail)	1.10kg		1.04kg	1.52kg	1.56kg
	KAW06-M (Panel Mount)	1.08kg		1.02kg	1.50kg	1.54kg

*1 Optional encoder cable is for incremental system.

*2 When constructing an absolute system, it is necessary to install a battery in the amplifier.

*3 Model numbers include Suruga Seiki's proprietary management codes.

- X
- XY
- Z
- Horizontal Z
- XYZ
- Goniometer
- Rotary
- Unit
- Controller

Ball Screw

Worm Gear

□40

□50

□60

□70

Motorized Stage

Goniometer Stage □60: KAW06 (2-axis)

Dimensions

KAW06-L Seires

Top view :KAW06□□□T-LC (Pigtail)

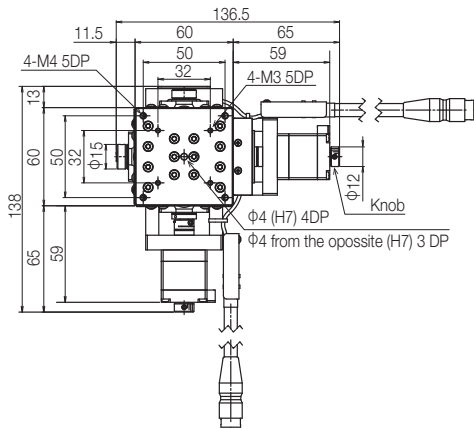

Side view :common

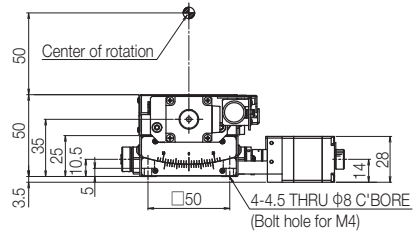

KAW06050T (M) -LC

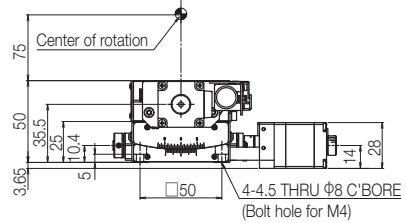

KAW06075T (M) -LC

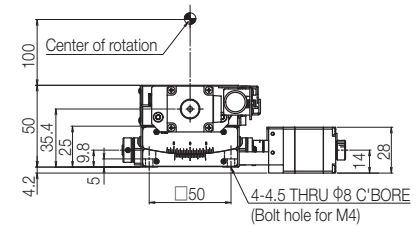

KAW06100T (M) -LC

Top view :KAW06□□□M-LC (Panel Mount)

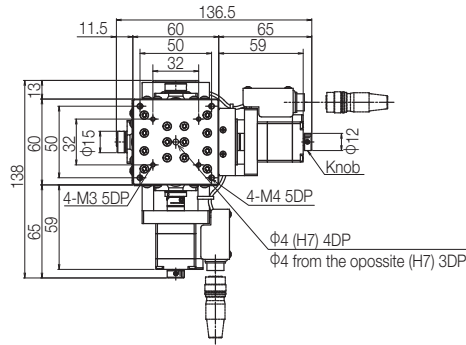

KAW06-R Series

Side view :common

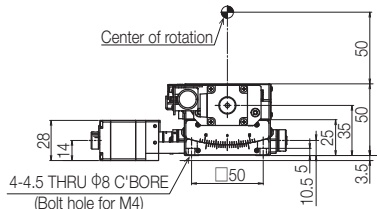

KAW06050T (M) -RC

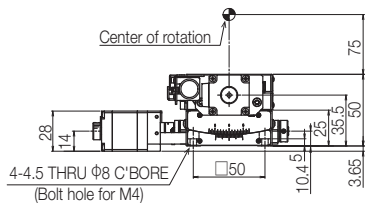

KAW06075T (M) -RC

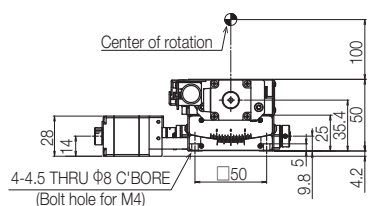

KAW06100T (M) -RC

Top view :KAW06□□□T-RC (Pigtail)

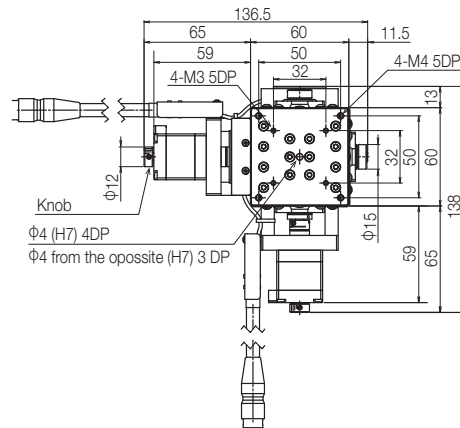

Top view :KAW06□□□M-RC (Panel Mount)

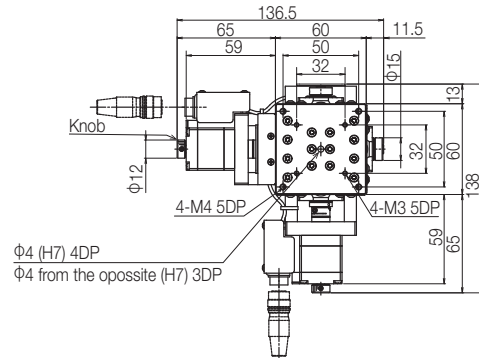

Motorized
goniometer Stage

X

XY

Z

Horizontal

Z

XYZ

Goniometer

Rotary

Unit

Controller

Ball
Screw

Worm
Gear

□40

□50

□60

□70

Dimensions

C Standard motor

Motor Model C005C-90215P-1

G High resolution

Motor Model PK523HPMB-C1

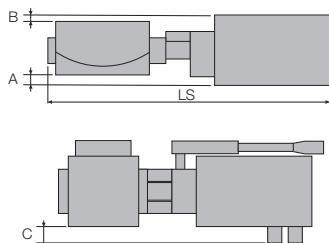

Model	Motor code	Motor size	Connector type	A(mm)	B(mm)	C(mm)	LS(mm)
KGW06050□-□□	C・G	□28	T・M	4.1	-	-	136.5
KGW06075□-□□				3.5			
KGW06100□-□□				3.7			
KGW06125□-□□				4.2			

EA Motor for EtherCAT

Motor Model STM28W100A

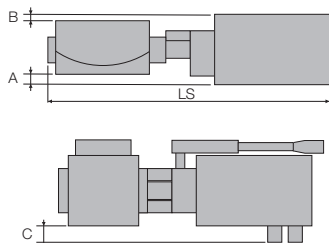

Model	Motor code	Motor size	Connector type	A(mm)	B(mm)	C(mm)	LS(mm)
KGW06050□-□EA	EA	□28	T・M	4.1	-	-	162.8
KGW06075□-□EA				3.5			
KGW06100□-□EA				3.7			
KGW06125□-□EA				4.2			

PA αSTEP (AR Series)

Motor Model ARM24SAK

ZA αSTEP (AZ Series)

Motor Model AZM24AK

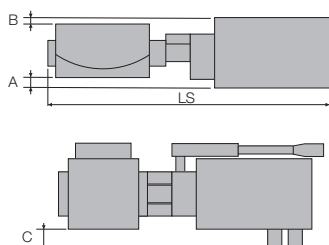

Model	Motor code	Motor size	Connector type	A(mm)	B(mm)	C(mm)	LS(mm)
KGW06050□-□PA	AR	□28	T・M	4.1	-	-	147.5
KGW06075□-□PA				3.5			
KGW06100□-□PA				3.7			
KGW06125□-□PA				4.2			
KGW06050□-□ZA	ZA	□28	T・M	4.1	-	-	157
KGW06075□-□ZA				3.5			
KGW06100□-□ZA				3.7			
KGW06125□-□ZA				4.2			

UG Servo motor MINAS A6 (Panasonic)

Motor Model MSMF5AZL1A2

UA Servo motor J4 (Mitsubishi Electric corporation)

Motor Model HG-KR053

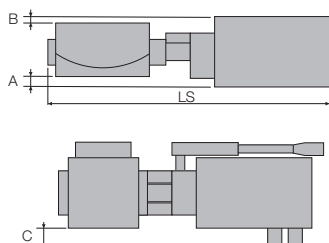

Model	Motor code	Motor size	Connector type	A(mm)	B(mm)	C(mm)	LS(mm)
KGW06050□-□UG	UG	□38	T・M	9.1	4	2	187.5
KGW06075□-□UG				8.5	4.5		
KGW06100□-□UG				8.7	4.4		
KGW06125□-□UG				9.2	3.8		
KGW06050□-□UA	UA	□40	T・M	10.4	5.3	-	181.9
KGW06075□-□UA				9.8	5.8		
KGW06100□-□UA				10	5.7		
KGW06125□-□UA				10.5	5.1		

X

XY

Z

Horizontal
Z

XYZ

Goniometer

Rotary

Unit

Controller

Ball
Screw

Worm
Gear

□40

□50

□60

□70

Goniometer Stage :KGW Series

Motor option

- C** Standard motor
Motor model
C005C-90215P-1
- G** High resolution
Motor model
PK523HPMB-C1

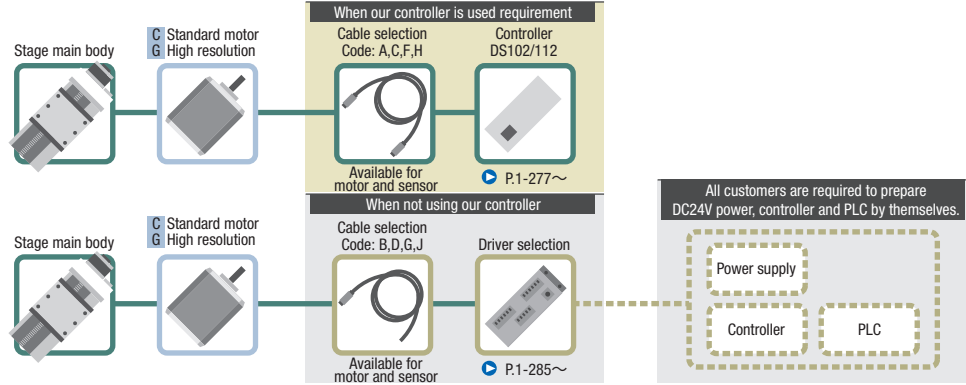

Motor option

- EA** Motor for EtherCAT
Motor model
STM28W100A

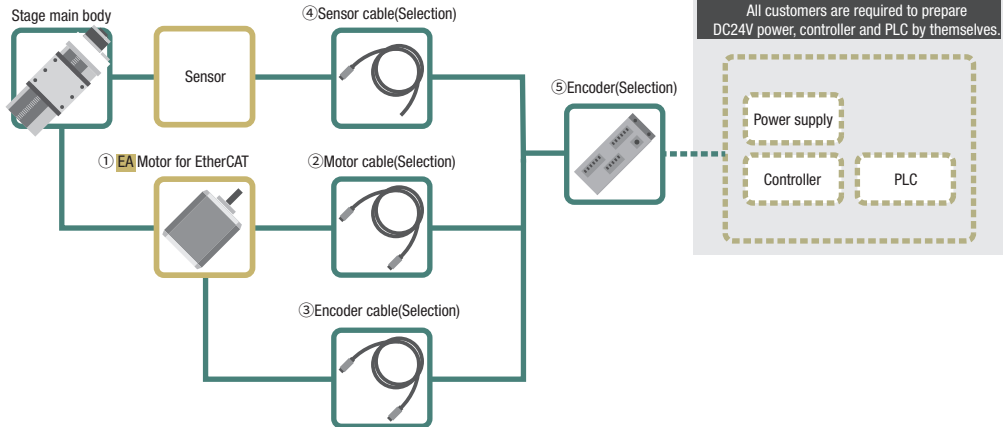

Code	① Motor model	② Motor cable selection	③ Encoder cable selection	④ Sensor cable selection	④ Driver selection
EA	STM28W100A	3A : D214-3-3R2 5A : D214-3-5R2 Blank · 3 · 5 : Not included	3A : D214-3-3RE2 5A : D214-3-5RE2 Blank · 3 · 5 : Not included	3A · 3 : HR10AP-S-SB-6-3 5A · 5 : HR10AP-S-SB-6-5 Blank : HR10AP-S-SB-6-2	3A · 5A : DS1000A-EC-28 Blank · 3 · 5 : Not included

Motor option

- PA** αSTEP (AR Series)
Motor model
ARM24SAK
- ZA** αSTEP (AZ Series)
Motor model
AZM24AK

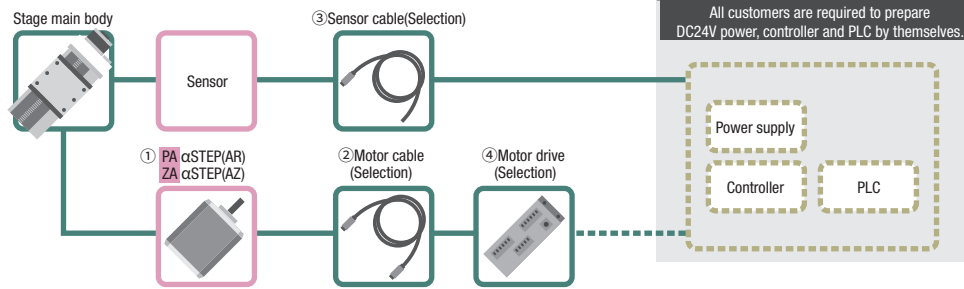

Code	① Motor model	② Motor cable selection	③ Sensor cable selection	④ Driver selection
PA	ARM24SAK	3A : CC030VA2R2 5A : CC050VA2R2 Blank · 3 · 5 : Not included	3A · 3 : HR10AP-S-SB-6-3 5A · 5 : HR10AP-S-SB-6-5 Blank : HR10AP-S-SB-6-2	3A · 5A : ARD-K Blank · 3 · 5 : Not included
ZA	AZM24AK	3A : CC030VZ2R2 5A : CC050VZ2R2 Blank · 3 · 5 : Not included		3A · 5A : AZD-K Blank · 3 · 5 : Not included

Motor option

- UG** Servo motor
Motor model
MSMF5AZL1A2
- UA** Servo motor
Motor model
HG-KR053

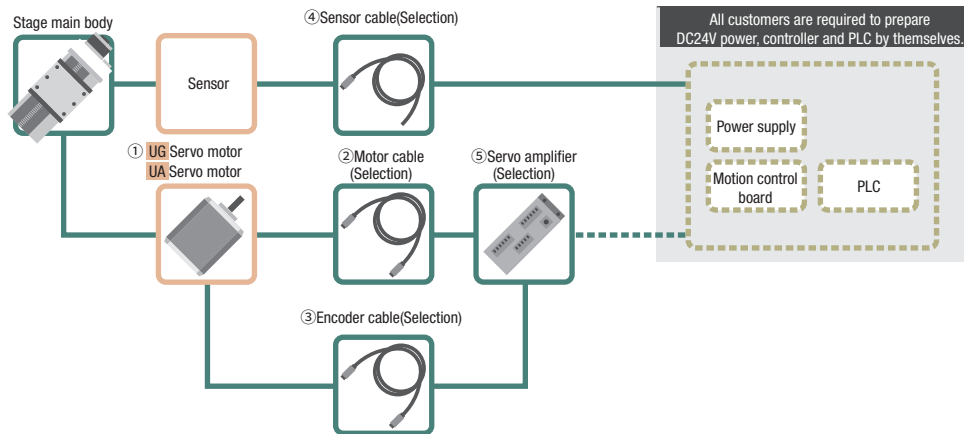

Code	① Motor model	② Motor cable selection	③ Encoder cable selection	④ Sensor cable selection	⑤ AC servo amplifier selection
UG	MSMF5AZL1A2	3A : MFMCA0030EED 5A : MFMCA0050EED Blank · 3 · 5 : Not included	3A : MFECA0030EAD 5A : MFECA0050EAD Blank · 3 · 5 : Not included	3A · 3 : HR10AP-S-SB-6-3 5A · 5 : HR10AP-S-SB-6-5 Blank : HR10AP-S-SB-6-2	3A · 5A : MADLT05SF Blank · 3 · 5 : Not included
UA	HG-KR053	3A : SVPM-J3HF1-B-3-02S 5A : SVPM-J3HF1-B-5-02S Blank · 3 · 5 : Not included	3A : SVEM-J3HF1-B-3 5A : SVEM-J3HF1-B-5 Blank · 3 · 5 : Not included		3A · 5A : MR-J4-10A Blank · 3 · 5 : Not included

- X
- XY
- Z
- Horizontal Z
- XYZ
- Goniometer
- Rotary
- Unit
- Controller

- Ball Screw

- Worm Gear

- 40
- 50
- 60
- 70

Goniometer Stage :KGW Series

Electrical specification(5 phase stepping motor/ α STEP)

Motor code		C	G	PA	ZA	
Model (*1)		KGW04/KGW06				
Motor Specification (*2)	Type	5 phase stepping motor (0.75A/Phase)		α STEP (AR Series)	α STEP (AZ Series)	
	Feature	Standard	High resolution	Small step-out_incremental	Small step-out_absolute	
	Model (*3)	C005C-90215P-1	PK523HPMB-C1	ARM24SAK	AZM24AK	
	With electromagnetic brake	-				
	Manufacturer	Oriental Motor Co., Ltd.				
	Step angle	0.72°	0.36°	0.36°(1000P/R setting)		
	Mass	0.11kg		0.15kg		
	Motor size	□ size	□28mm		□28mm	
		L size	37mm		45mm	54.5mm
	Max. Holding Torque	0.048N · m	0.038N · m	0.055N · m	0.095N · m	
Driver model	CVD507-K-A9		ARD-K	AZD-K		
Input power (Voltage · frequency)	DC24V \pm 10% 1.4A(MAX)		DC24V \pm 10%	DC24V \pm 5%		
Connector	Pigtail	HR10A-10J-12P(73) (Hirose Electric Co., Ltd.)		Motor:43025-1000 (MOLEX) or 1-794617-0(TE Connectivity) Sensor:HR10A-7J-6P(73)(HRS)	Motor:DF62B-13EP-2.2C(HRS) Sensor:HR10A-7J-6P(73)(HRS)	
	Panel Mount	HR10A-10R-12P(73) (Hirose Electric Co., Ltd.)		Motor:43025-1000 (MOLEX) or 1-794617-0(TE Connectivity) Sensor:HR10A-7R-6P(73)(HRS)	Motor:DF62B-13EP-2.2C(HRS) Sensor:HR10A-7R-6P(73)(HRS)	
	Receiving connector	HR10A-10P-12S(73) (Hirose Electric Co., Ltd.)		Motor:43025-1000 (MOLEX) or 1-794615-0(TE Connectivity) Sensor:HR10A-7P-6S(73) (HRS)	Motor:DF62C-13S-2.2C(HRS) Sensor:HR10A-7P-6S(73)(HRS)	
Sensor board	Limit sensor	Available				
	Origin sensor	Available				
	Slit origin sensor	-				
	Sensor model	Photo microsensor EE-SX4320 (Omron Co., Ltd.)				
	Power-supply voltage	DC5~24V \pm 5%				
	Current consumption	Total 60mA or less				
	Control output	NPN open collector output DC30V 10mA or less				
Output logic	On detection (light shield condition): Output transistor OFF (Non-continuity)					

(*1) The electric specification of 2-axis Goniometer Stage (KAW) is the same.

(*2) See page P.1-297~ for details of single motor specification.

(*3) Model numbers include Suruga Seiki's proprietary management codes.

Pin allocation · Connection diagram

[Pin allocation (common)]

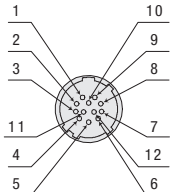
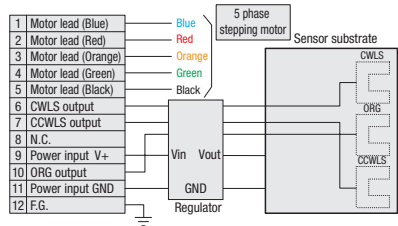
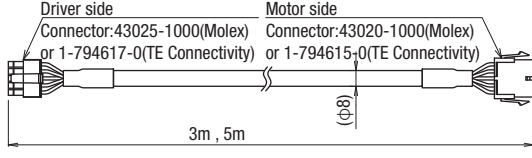
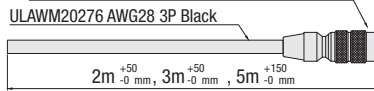
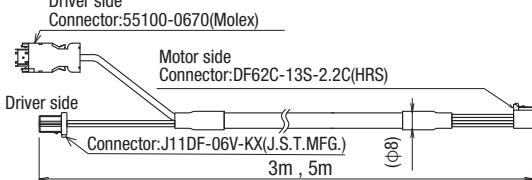
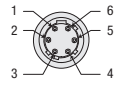
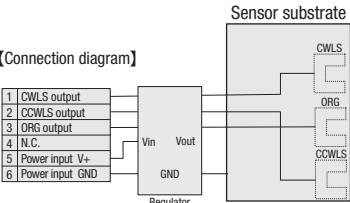
Motor Code	KGW Series																
C · G	Available for motor and sensor	<p>[Pin allocation (common)]</p> <p>Pigtail : HR10A-10J-12P(73) (HRS) Panel Mount : HR10A-10R-12P(73) (HRS)</p> 	<p>[Pin allocation (common)]</p> 														
		PA	Motor	<p>[Receiver cable] Model:CC030VA2R2(3m)/CC050VA2R2(5m) *Flexible cable</p> 	<p><Sensor (common)></p> <p>[Receiver cable] Model:HR10AP-S-SB-6-□ (□ is the length) *for fixing Sensor side Connector (Female): HR10A-7P-6S (73) (HRS) ULAWM20276 AWG28 3P Black</p>  <p>*The shields are connected with the connector shell.</p> <table border="1"> <tr> <th>Pin</th> <th>Signals</th> </tr> <tr> <td>1</td> <td>CWLS</td> </tr> <tr> <td>2</td> <td>CCWLS</td> </tr> <tr> <td>3</td> <td>ORG</td> </tr> <tr> <td>4</td> <td>NORG</td> </tr> <tr> <td>5</td> <td>V+</td> </tr> <tr> <td>6</td> <td>V-</td> </tr> </table>	Pin	Signals	1	CWLS	2	CCWLS	3	ORG	4	NORG	5	V+
Pin	Signals																
1	CWLS																
2	CCWLS																
3	ORG																
4	NORG																
5	V+																
6	V-																
ZA	Motor	<p>[Receiver cable] Model:CC030VZ2R2(3m)/CC050VZ2R2(5m) *Flexible cable</p> 	<p>[Pin allocation (common)]</p> <p>Pigtail:HR10A-7J-6P(73) (HRS) Panel Mount:HR10A-7R-6P(73) (HRS)</p>  <p>[Connection diagram]</p> 														

Electrical specification (Motor for EtherCAT/Servo motor)		EA	UG	UA	
Motor code					
Model			KGW04/KGW06		
Motor Specification	Type	2 phase closed Loop stepping motor	Servo motor	Servo motor	
	Feature	Small step-out ,incremental,EtherCAT	High speed	High speed	
	Model	STM28W100A	MSMFAZL1A2	HG-KR053	
	With electromagnetic brake		—		
	Manufacturer	SURUGA SEIKI	Panasonic	Mitsubishi Electric corporation	
	Step angle	0.36° (1000P/R setting)	Both absolute and incremental 23 bits encoder (8388608P/R) (*1)	Both absolute and incremental 22 bits encoder (4194304P/R) (*2)	
	Mass	0.12kg	0.32kg	0.34kg	
	Motor size	□ size	□28mm	□38mm	□40mm
		L size	59.3mm	72mm	66.4mm
	Max. Holding Torque	0.085N · m	—	—	
Maximum torque	—	0.48N · m	0.56N · m		
Driver model	DS1000A-EC-28	MADLT05SF	MR-J4-10A		
Input power (Voltage · frequency)	DC24V±10%	Three and Single phase AC200-240V 50/60Hz	Three and Single phase AC200-240V 50/60Hz		
Connector	Pigtail	Motor:B06B-ZESK-D (JST) Encoder:SM08B-GHS-TB (JST) Sensor:HR10A-7J-6P(73)(HRS) Driver I/O Connector Housing:PUDP-24V-S Driver I/O Contact:SPUD-002T-P0.5:SPUD-002T-P0.5	Motor: 172167-1(TE Connectivity) Encoder: 172169-1(TE Connectivity) Sensor:HR10A-7J-6P(73)(HRS)	Motor: Manufacturer standard Encoder: Manufacturer standard Sensor:HR10A-7J-6P(73) (HRS)	
	Panel Mount	Motor:B06B-ZESK-D (JST) Encoder:SM08B-GHS-TB (JST) Sensor:HR10A-7R-6P(73)(HRS) Driver I/O Connector Housing:PUDP-24V-S Driver I/O Contact:SPUD-002T-P0.5	Motor: 172167-1 (TE Connectivity) Encoder: 172169-1 (TE Connectivity) Sensor:HR10A-7R-6P(73)(HRS)	Motor: Manufacturer standard Encoder: Manufacturer standard Sensor:HR10A-7R-6P(73)(HRS)	
	Receiving connector	Motor:ZER-06V-S (JST) Encoder:GHR-08V-S (JST) Sensor:HR10A-7P-6S(73)(HRS)	Motor: 172159-1 (TE Connectivity) Encoder: 172161-1 (TE Connectivity) Sensor:HR10A-7P-6S(73)(HRS)	Motor:JN4FT04SJ1-R (JST) Encoder: 1674320-1 (TE Connectivity) Sensor:HR10A-7P-6S(73)(HRS)	
Sensor board	Limit sensor		Available		
	Origin sensor		Available		
	Slit origin sensor		—		
	Sensor model		Photo microsensor EE-SX4320 (Omron Co., Ltd.)		
	Power-supply voltage		DC5~24V±5%		
	Current consumption		Total 60mA or less		
	Control output		NPN open collector output DC30V 10mA or less		
	Output logic		On detection (light shield condition): Output transistor OFF (Non-continuity)		

(*1) Optional encoder cable is for incremental system.

(*2) When constructing an absolute system, it is necessary to install a battery in the amplifier.

Pin allocation · Connection diagram

Motor Code	Motor · Encoder	Sensor (common)
EA	Motor [Receiver cable] Model:D214-3-3R2(3m)/D214-3-5R2(5m) *Flexible cable Driver side Connector:PAP-04V-S(J.S.T.MFG.) Contact:SPHD-002T-P0.5(J.S.T.MFG.) Motor side Connector:ZER-06V-S(J.S.T.MFG.) Contact:SZE-002T-P0.3(J.S.T.MFG.) 	Encoder [Receiver cable] Model:D214-3-3RE2(3m)/D214-3-5RE2(5m)*Flexible cable Driver side Connector:PUDP-10V-S(J.S.T.MFG.) Contact:SPUD-002T-P0.5(J.S.T.MFG.) Motor side Connector:GHR-08V-S(J.S.T.MFG.) Contact:SHL-002T-P0.2(J.S.T.MFG.)
	Encoder [Receiver cable] Model:D214-3-3R2(3m)/D214-3-5R2(5m)*Flexible cable 	
UG	Motor [Receiver cable] Model:MFCA0030EED(3m)/MFCA0050EED(5m)*Flexible cable 	Encoder [Receiver cable] Model:MFCA0030EAD(3m)/MFCA0050EAD(5m) *for fixing
	Encoder [Receiver cable] Model:MFCA0030EAD(3m)/MFCA0050EAD(5m) *for fixing 	
UA	Motor [Receiver cable] Model:SVPM-J3HF1-B-□-02S *Flexible cable Loose wire on the servo amplifier side: 200mm Motor side Connector: JN4FT04SJ1-R (JAE) NA3CTR-18-4(MISUMI) ULAWM2517 AWG18 +30 3m -0 mm, 5m -0 mm +150 -0 mm	Motor [Receiver cable] Model:SVPM-J3HF1-B-□-02S *Flexible cable Servo amplifier side Receptacle: 36210-0100FD (3M) ShellKit : 36310-3200-008 (3M) Motor (encoder)side Connector:1674320-1 (TE Connectivity) NAMFSB-23-3P (MISUMI) ULAWM2576 AWG23 +50 3m -0 mm, 5m -0 mm * The load drawer
	Encoder [Receiver cable] Model:SVPM-J3HF1-B-□-02S *Flexible cable 	

Sensor (common)

[Receiver cable] Model:HR10AP-SB-6-□ (□ is the length) *for fixing

Sensor side Connector (Female): HR10A-7P-6S (73) (HRS)
ULAWM20276 AWG28 3P Black

2m +50 -0 mm, 3m +50 -0 mm, 5m +150 -0 mm

Pin	Signals
1	CWLS
2	CCWLS
3	ORG
4	NORG
5	V+
6	V-

*The shields are connected with the connector shell.

[Pin allocation]
Pigtail:HR10A-7J-6P(73) (HRS) Panel Mount:HR10A-7R-6P(73) (HRS)

Sensor substrate

[Connection diagram]

X

XY

Z

Horizontal
Z

XYZ

Goniometer

Rotary

Unit

Controller

Ball
Screw

Worm
Gear

□ 40

□ 50

□ 60

□ 70

Connectin example

■ Connection example 1 Motorized Stage 1axis: When holding a terminal device (using control software)

*USB cable connection between PC and controller.

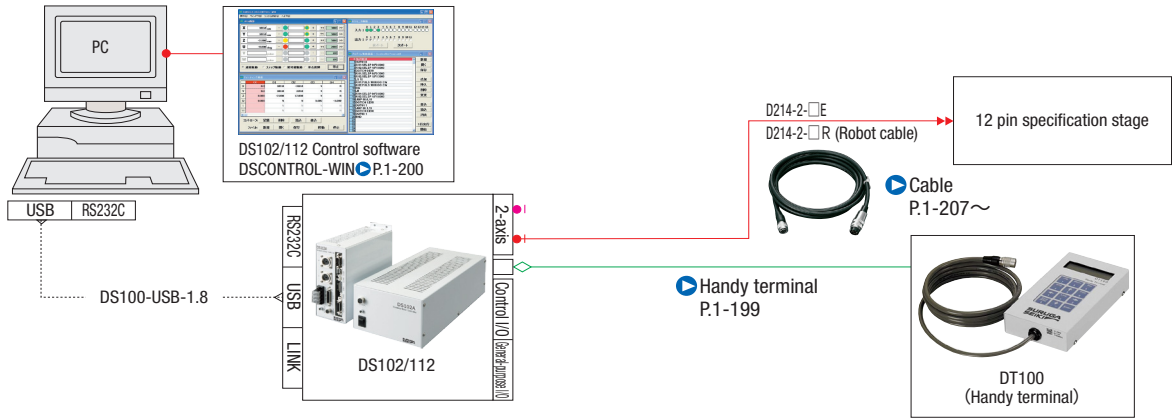

■ Connection example 2 Motorized Stage 4axis: When holding a terminal device (using control software)

*USB cable connection between PC and controller.

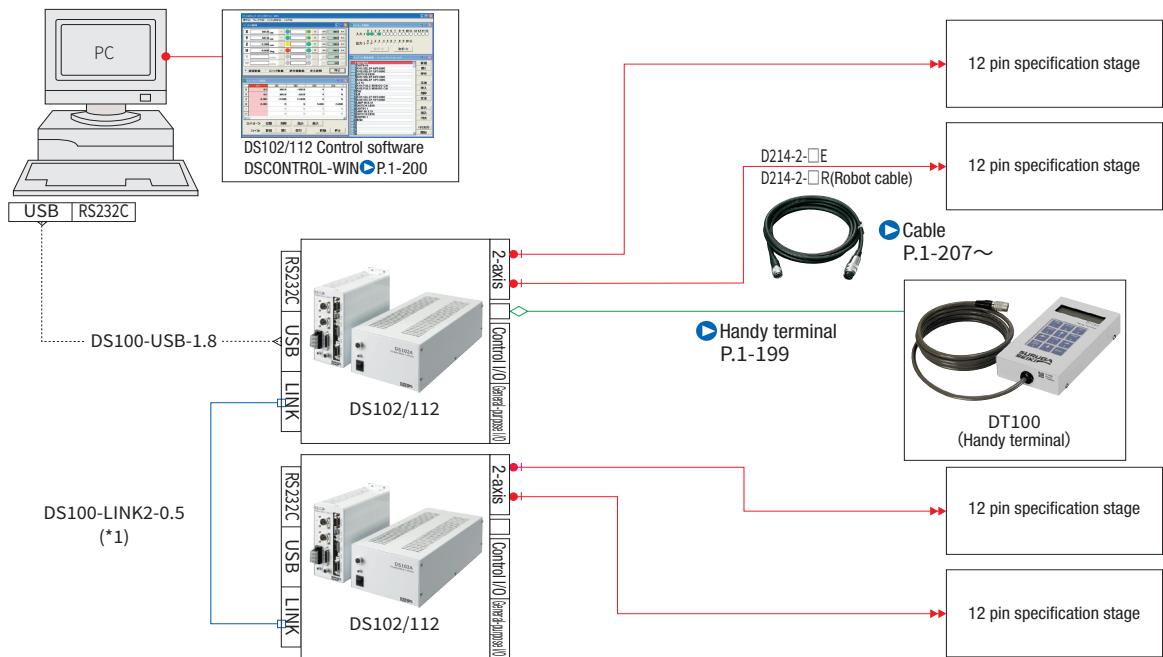

(*1) It is possible to control up to 3 controllers (for a maximum of 6-axis control) with link function.

■ Connection example 3 When controlling from the PLC I/O Unit.

*USB cable connection between PC and controller.

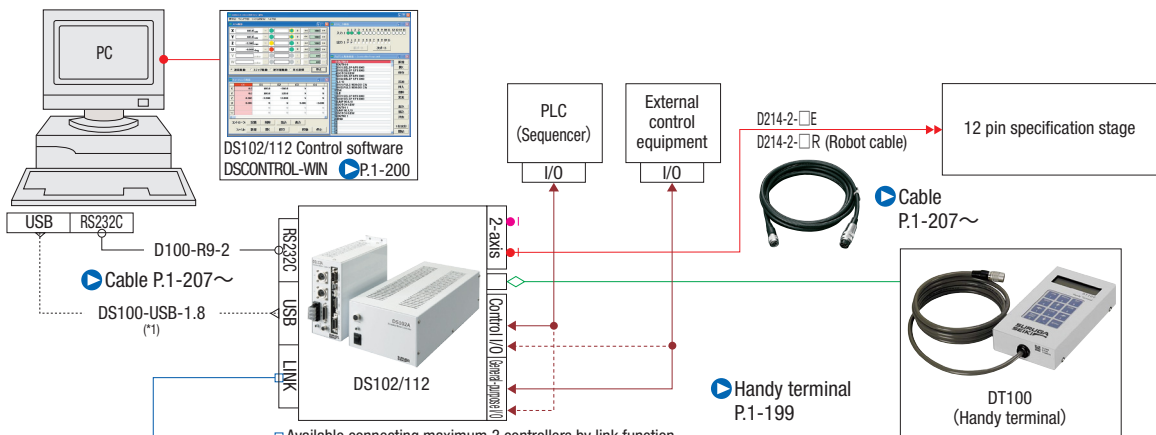

(*1) Using the USB hub, it is controllable in a single PC to up to four link networks (24-axis).

Goniometer Stage □50: KG05 (1-Axis)/KA05 (2-Axis)

■ 1-Axis
KG05

■ 2-Axis
KA05

RoHS

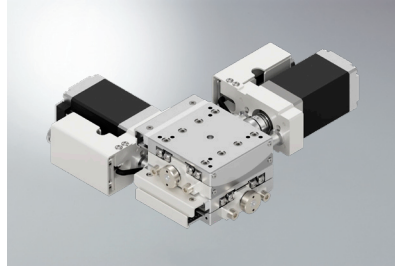
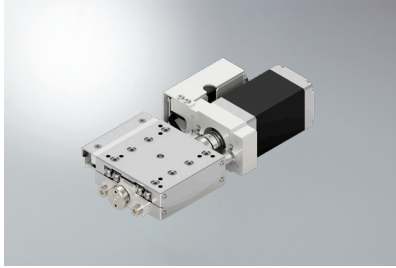

■ Our high precision goniometer stages based on cross roller guide for travel guide and worm gear mechanism.

■ High performance with runout accuracy of center rotation within 0.01 mm.

■ Configuration 2-axis
Combination of 1-axis stage that is different center of rotation.

* All image is for illustrative purposes only.

KG05-W050AL-H5

1

2

3

4

5

Calbes P.1-287~

Electrical specification P.1-233~

1 Axis

G	1-axis
A	2-axis

3 Sensor cover location specification

Code	Specification
L	L position
R	Opposite hand

5 Calbe option

Code	Specification	Cable type
Blank	2m	D214-2-2E
1	2m One end loose	D214-2-2EK
2	4m	D214-2-4E
3	4m One end loose	D214-2-4EK
4	Only connector (Cable is not included)	—
5	Cable is not included (Standard)	—
6	Robot cable 2m	D214-2-2R
7	Robot cable 4m	D214-2-4R
8	Robot cable 4m one end loose	D214-2-4RK
9	Robot cable 2m one end loose	D214-2-2RK

2 Height of center rotation (W.D.)

050	50mm
068	68mm
086	86mm

* Unselectable 086 for 2-axis

4 Motor option

Code	Specification
H	<input type="checkbox"/> 28 High resolution
G	<input type="checkbox"/> 42 High resolution

* There is no difference in accuracy specifications depending on the selected motor. Only the weight and external dimensions differ. For details, please check the CAD and external dimensions.

* One end loose position to only stage opposite side.

* Please select "blank, 2, 6 and 7" when connect with stepping motor controller(DS102/112).

Selection Example

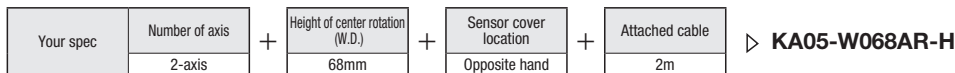

		SPEC					
		1-axis			2-axis		
Model		KG05-W050AL-H5	KG05-W068AL-H5	KG05-W086AL-H5	KA05-W050AL-H5	KA05-W068AL-H5	
(Opposite hand)		KG05-W050AR-H5	KG05-W068AR-H5	KG05-W086AR-H5	KA05-W050AR-H5	KA05-W068AR-H5	
Mechanical specification	Travel length Upper/Lower axis	$\pm 10^\circ$		$\pm 8^\circ$	$\pm 10^\circ/\pm 8^\circ$		
	Table size	50×50mm					
	Travel mechanism (Reduction ratio)	Upper	Worm gear (1/231)	Worm gear (1/300)	Worm gear (1/375)	Worm gear (1/231)	Worm gear (1/300)
		Lower				Worm gear (1/300)	Worm gear (1/375)
Guide	Crossed roller guide						
Main materials-Finishing	Brass/Phosphor bronze—Nickel chrome plating						
Weight	0.63kg * 0.76 kg (with Motor Code G selected)			1.26kg * 1.52 kg (with Motor Code G selected)			
Universal feature	Height of stage	18±0.2mm			36±0.4mm		
	Height of center rotation	50±0.2mm	68±0.2mm	86±0.2mm	50±0.4mm	68±0.4mm	
	Runout accuracy of center rotation	0.01mm					
Accuracy specification	Resolution/Pulse	Upper at the full	0.001559°	0.0012°	0.00096°	0.001559°	
		Lower at the full				0.0012°	0.00096°
	MAX speed	Upper	7.8°/sec [5kHz]	6°/sec [5kHz]	4.8°/sec [5kHz]	7.8°/sec [5kHz]	6°/sec [5kHz]
		Lower				6°/sec [5kHz]	4.8°/sec [5kHz]
	Repeatability positioning accuracy	$\pm 0.005^\circ$					
Load capacity	3kgf [29.4N]			2.4kgf [23.5N]			
Moment stiffness	Pitch 0.42/yaw 0.16/roll 0.23 ["/N · cm]						
Loss motion	0.01°						
Sensor	Limit sensor	Installed					
	Origin sensor	Installed					
	Slit origin sensor	—					
Provided screw (Hexagon-headed bolt)	4 of M3-6						

※ Might be changed specification due to motors.

X

XY

Z

Horizontal

Z

XYZ

Goniometer

Rotary

Unit

Controller

Ball Screw

Worm Gear

□40

□50

□60

□70

Electrical Specification: KG05/KA05

Electrical specification

Model	KG05-W050AL-G	KG05-W068AL-G	KG05-W086AL-G
Opposite hand	KG05-W050AR-G	KG05-W068AR-G	KG05-W086AR-G
Motor (*1)	Type	5 phase stepping motor 0.75A/Phase (Oriental Motor Co., Ltd.)	
	Model (*2)	PK544PMB-C18(□42mm)	
	Step angle	0.36°	
Connector	Model	HR10A-10R-12P (73) (Hirose Electric Co., Ltd.)	
	Applicable connector on acceptance side	HR10A-10P-12S (73) (Hirose Electric Co., Ltd.)	
Sensor	Limit sensor	Installed	
	Origin sensor	Installed	
	Slit origin sensor	-	
	Model	Photo microsensor: EE-SX4320 (Omron Co., Ltd.)	
	Power voltage	DC5~24V ±10%	
	Consumption current	Total 60mA or less	
	Control output	NPN open collector output DC5~24V 8mA or less Residual voltage 0.4V or less when the load current is 8mA	
Output logic	On detection (light shield condition): Output transistor OFF (Non-continuity)		

*1 See page P.1-297~ for details of single motor specification.

*2 Model numbers include Suruga Seiki's proprietary management codes.

Pin allocation

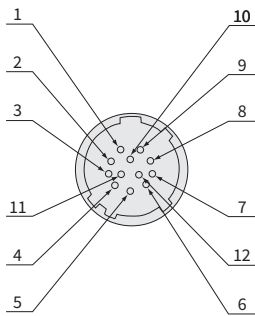

Connection diagram

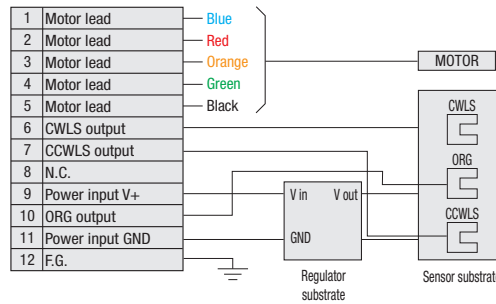

50 goniometer sensor logic

Type	CWLS	ORG	CCWLS
A	N.C. EE-SX4320	N.C. EE-SX4320	N.C. EE-SX4320

* Upper: Sensor logic
Lower: Using sensor

Note: Only 50 goniometer stage sensor logic

Timing chart

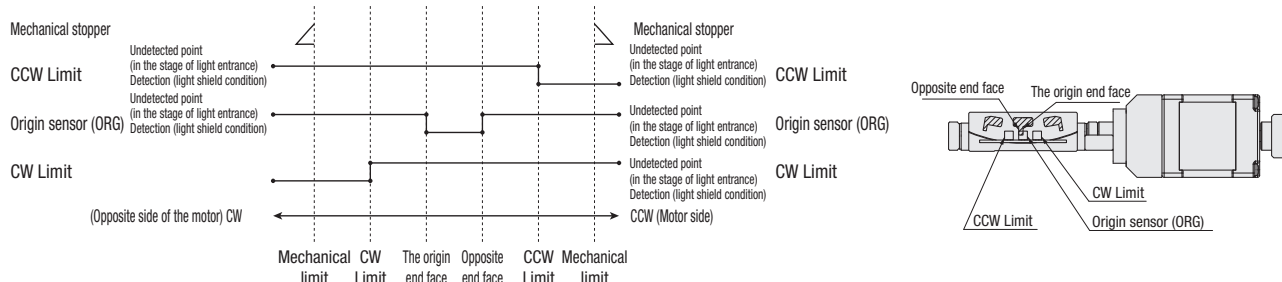

Unit [deg]	Reference coordinate	Direction of CW ← → Direction of CCW			
		CW Limit	Origin	Opposite end face	CCW Limit
KG05-W050A	Return to origin	10.3	0	1.9	10.3
KG05-W068A	Return to origin	8.3	0	1.5	8.3
KG05-W086A	Return to origin	6.3	0	1.2	6.3

* Return to origin means that is performed return to origin Type 4 using DS102/DS112 series.
 * The coordinate value should be on the design. Dimension error may occur about plus or minus 0.5 deg.

Method for return to origin

Suruga's motorized stages are different from the specification depending on the models. Therefore return to origin method other than recommendation may not be work correctly. Set to the way of recommendation return origin when using our controller.

KG05/KA05 recommended return to origin Return to origin sequence P.1-281~

- Type 3: Detect in the direction of CCW and perform detected process for CCW edge (a point) of ORG signal.
- Type 4: Detect in the direction of CW and perform detected process for CW edge of ORG signal.
- Type 9: After finished Type3, perform detected process for CCW edge of TIMING signal.
- Type 10: After finished Type4, perform detected process for CW edge of TIMING signal.

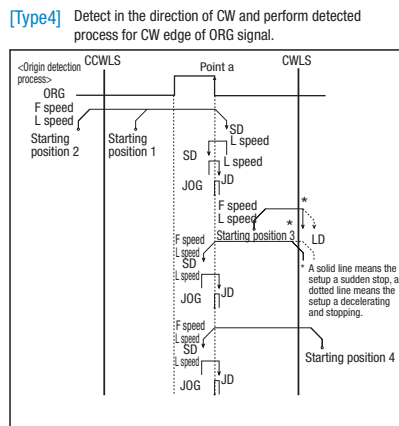
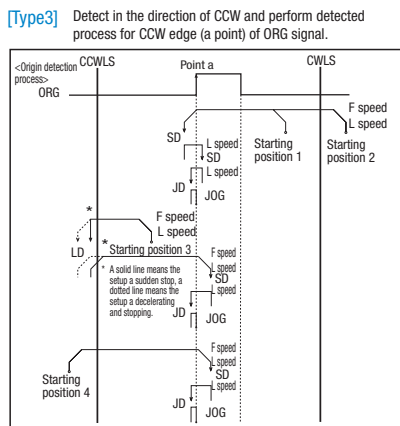

**Motorized
goniometer Stage**

- X
- XY
- Z
- Horizontal Z
- XYZ
- Goniometer
- Rotary
- Unit
- Controller
- Ball Screw
- Worm Gear
- 40
- 50
- 60
- 70
- 1
230

Goniometer Stage □70: KG07(1-Axis)/KA07(2-Axis)

1-Axis
KG07

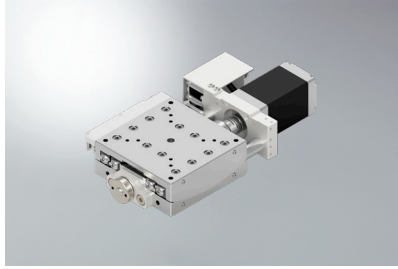

2-Axis
KA07

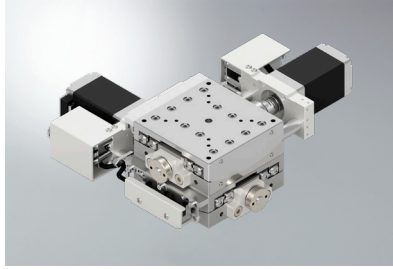

RoHS

- Our high precision goniometer stages based on cross roller guide for travel guide and worm gear mechanism.
- 70*70mm has an additional sensor logic system.
- Configuration 2-axis
Combination of 1-axis stage that is different center of rotation.

* All image is for illustrative purposes only.

KG07-W070AL-H5

1

2

3

4

5

6

Calbes P.1-287~
Electrical specification P.1-233~

1 Axis

G	1-axis
A	2-axis

2 Height of center rotation (W.D.)

070	70mm
096	96mm
122	122mm

* KA07 is only W.D.70 and 96mm

3 Sensor logic

Type	CWLS	ORG	CCWLS
A	N.C.	N.C.	N.C.
B	N.O.	N.O.	N.O.
C	N.C.	N.O.	N.C.

4 Sensor cover location specification

Code	Specification
L	L position
R	Opposite hand

5 Motor option

Code	Specification
H	<input type="checkbox"/> 28 High resolution
G	<input type="checkbox"/> 42 High resolution

* There is no difference in accuracy specifications depending on the selected motor. Only the weight and external dimensions differ. For details, please check the CAD and external dimensions.

6 Calbe option

Code	Specification	Cable type
Blank	2m	D214-2-2E
1	2m One end loose	D214-2-2EK
2	4m	D214-2-4E
3	4m One end loose	D214-2-4EK
4	Only connector (Cable is not included)	—
5	Cable is not included (Standard)	—
6	Robot cable 2m	D214-2-2R
7	Robot cable 4m	D214-2-4R
8	Robot cable 4m one end loose	D214-2-4RK
9	Robot cable 2m one end loose	D214-2-2RK

* One end loose position to only stage opposite side.

* Please select "blank, 2, 6 and 7" when connect with stepping motor controller(DS102/112).

Selection Example

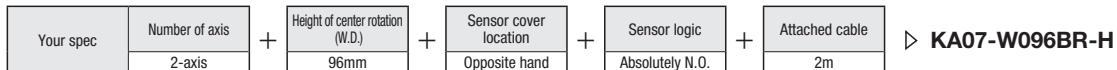

		SPEC					
Number of axis		1-axis			2-axis		
Model		KG07-W070AL-H5	KG07-W096AL-H5	KG07-W122AL-H5	KA07-W070AL-H5	KA07-W096AL-H5	
(Opposite hand)		KG07-W070AR-H5	KG07-W096AR-H5	KG07-W122AR-H5	KA07-W070AR-H5	KA07-W096AR-H5	
Mechanical specification	Travel length Upper/Lower axis	±9°	±7°	±5°	±9°/±7°	±7°/±5°	
	Table size	70×70mm					
	Travel mechanism (Reduction ratio)	Upper Lower	Worm gear (1/235)	Worm gear (1/301)	Worm gear (1/375)	Worm gear (1/235) Worm gear (1/301)	Worm gear (1/301) Worm gear (1/375)
	Guide	Crossed roller guide					
Main materials-Finishing		Aluminum-White almite finish					
Weight		0.82kg * 0.97 kg (with Motor Code G selected)			1.64kg * 1.94 kg (with Motor Code G selected)		
Dimensional tolerance	Height of stage	26±0.2mm			52±0.4mm		
	Height of center rotation	70±0.2mm	96±0.2mm	122±0.2mm	70±0.4mm	96±0.4mm	
	Runout accuracy of center rotation	0.01mm					
Accuracy specification	Resolution (Pulse)	Upper at the full Lower at the full	0.001532° 0.001196°	0.00096°	0.001532° 0.001196°	0.001196° 0.00096°	
	MAX speed	Upper Lower	7.6°/sec [5kHz] 6°/sec [5kHz]	4.8°/sec [5kHz]	7.6°/sec [5kHz] 6°/sec [5kHz]	6°/sec [5kHz] 4.8°/sec [5kHz]	
	Repeatability positioning accuracy	±0.003°					
	Load capacity	5kgf [49N]			4.2kgf [41.2N]		
Moment stiffness		Pitch 0.17/yaw 0.06/roll 0.06 ["/N · cm]					
Lost motion		0.006°					
Sensor	Limit sensor	Installed					
	Origin sensor	Installed					
	Slit origin sensor	-					
Provided screw (Hexagon-headed bolt)		4 of M4-8					

※ Might be changed specification due to motors.

X

XY

Z

Horizontal

Z

XYZ

Goniometer

Rotary

Unit

Controller

Ball Screw

Worm Gear

□40

□50

□60

□70

Dimensions (1-Axis)

KG07-WL-H (□28 Motor) series

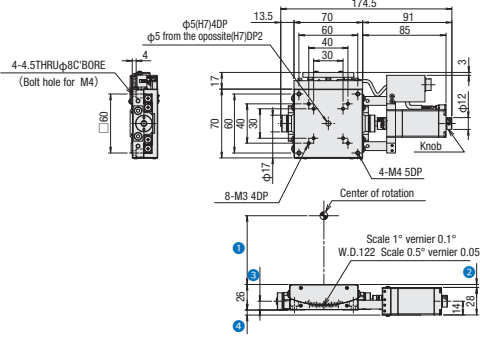

Model	1 W.D.	2	3	4
KG07-W070AL-H5	70	3.1	8.9	5.1
KG07-W096AL-H5	96	0.2	11.8	2.2
KG07-W122AL-H5	122	0.1	11.9	2.1

(mm)

KG07-WL-G (□42 Motor) series

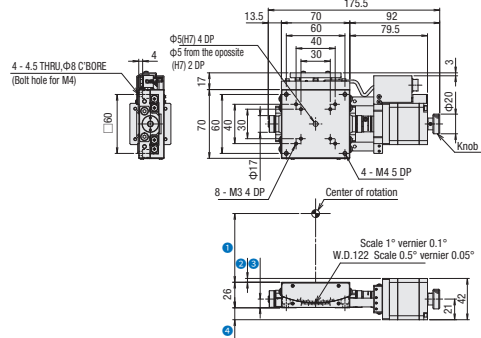

Model	1 W.D.	2	3	4
KG07-W070AL-G5	70	3.9	8.9	12.1
KG07-W096AL-G5	96	6.8	11.8	9.2
KG07-W122AL-G5	122	6.9	11.9	9.1

(mm)

KG07-WR-H (□28 Motor) series

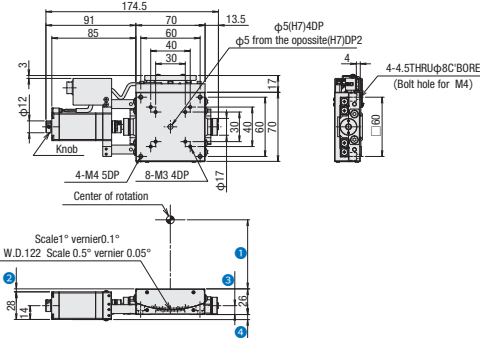

Model	1 W.D.	2	3	4
KG07-W070AR-H5	70	3.1	8.9	5.1
KG07-W096AR-H5	96	0.2	11.8	2.2
KG07-W122AR-H5	122	0.1	11.9	2.1

(mm)

KG07-WR-G (□42 Motor) series

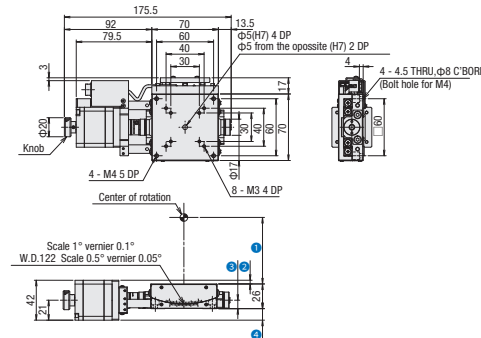

Model	1 W.D.	2	3	4
KG07-W070AR-G5	70	3.9	8.9	12.1
KG07-W096AR-G5	96	6.8	11.8	9.2
KG07-W122AR-G5	122	6.9	11.9	9.1

(mm)

Dimensions (2-Axis)

KA07-WL-H (□28 Motor) series

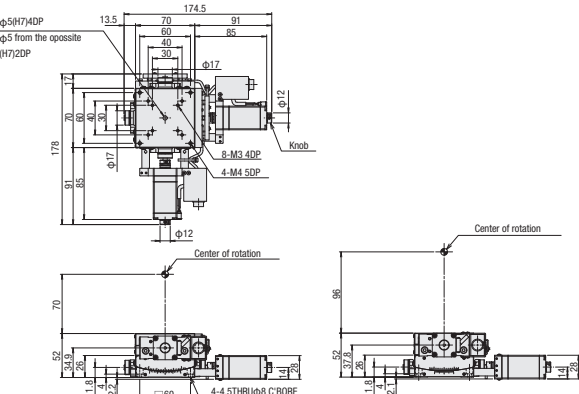

KA07-W070AL-H5

KA07-W096AL-H5

KA07-WL-G (□42 Motor) series

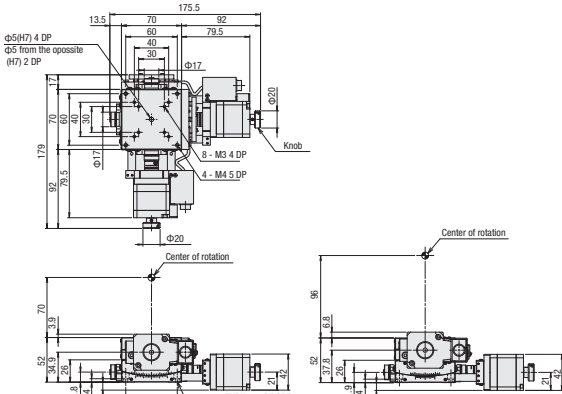

KA07-W070AL-G5

KA07-W096AL-G5

KA07-WR-H (□28 Motor) series

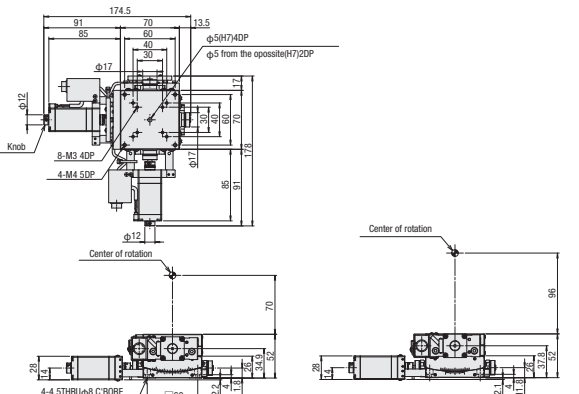

KA07-W070AR-H5

KA07-W096AR-H5

KA07-WR-G (□42 Motor) series

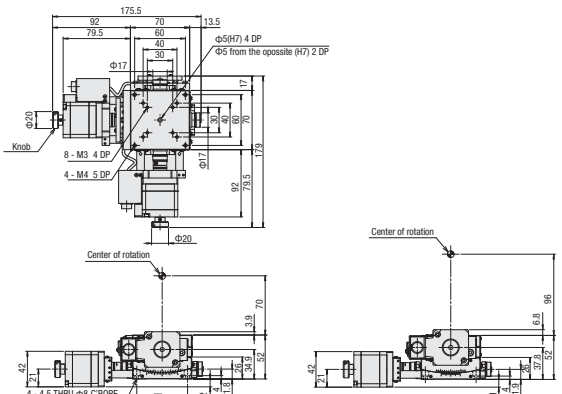

KA07-W070AR-G5

KA07-W096AR-G5

X

XY

Z

Horizontal

Z

XYZ

Goniometer

Rotary

Unit

Controller

Ball
Screw

Worm
Gear

□40

□50

□60

□70

1

232

Electrical Specification: KG07/KA07

Electrical specification

Model		KG07-W070AL-H	KG07-W096AL-H	KG07-122AL-H	KG07-W070AL-G	KG07-W096AL-G	KG07-122AL-G
Opposite hand		KG07-W070AR-H	KG07-W096AR-H	KG07-122AR-H	KG07-W070AR-G	KG07-W096AR-G	KG07-122AR-G
Motor (*1)	Type	5 phase stepping motor 0.75A/Phase (Oriental Motor Co., Ltd.)					
	Model (*2)	PK525HPMB-C1(□28mm)			PK544PMB-C18(□42mm)		
	Step angle	0.36°					
Connector	Model	HR10A-10R-12P (73) (Hirose Electric Co., Ltd.)					
	applicable connector on acceptance side	HR10A-10P-12S (73) (Hirose Electric Co., Ltd.)					
Sensor	Limit sensor	Installed					
	Origin sensor	Installed					
	Slit origin sensor	-					
	Model	Photo microsensor: EE-SX398, EE-SX498 (Omron Co., Ltd.)					
	Power voltage	DC5~24V ±10%					
	Consumption current	Total 85mA or less					
	Control output	NPN open collector output DC5V~24V 16mA or less Residual voltage 0.4V or less when the load current is 16mA					
	Output logic	EE-SX398: On detection (light shield condition): Output transistor ON (Continuity) EE-SX498: On detection (light shield condition): Output transistor OFF (Non-continuity)					

*1 See page P.1-208~ for details of single motor specification.

*2 Model numbers include Suruga Seiki's proprietary management codes.

* The electric specification of the 2-axis KA07 series are the same.

Pin allocation

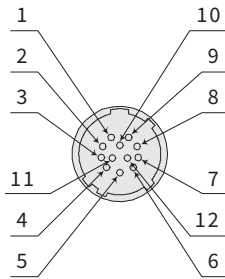

Connection diagram

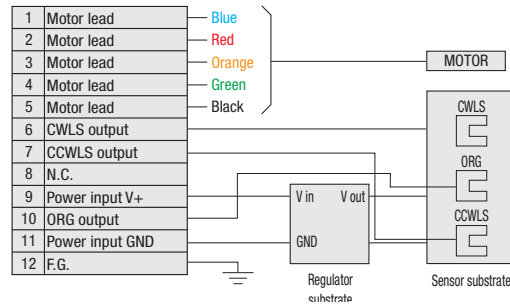

70 goniometer sensor logic

Type	CWLS	ORG	CCWLS
A	N.C. EE-SX498	N.C. EE-SX498	N.C. EE-SX498
B	N.O. EE-SX398	N.O. EE-SX398	N.O. EE-SX398
C	N.C. EE-SX498	N.O. EE-SX398	N.C. EE-SX498

X

XY

Z

Horizontal

Z

XYZ

Goniometer

Rotary

Unit

Controller

Ball
Screw

Worm
Gear

□40

□50

□60

□70

Timing chart

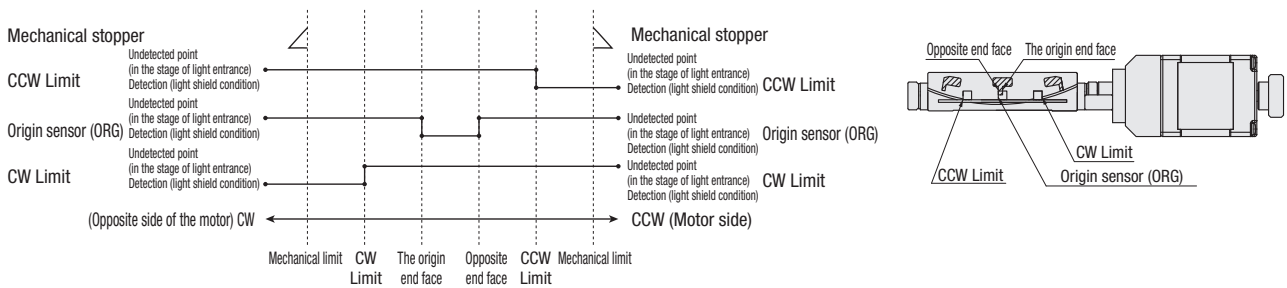

Unit [deg]	Direction of CW ← → Direction of CCW				
	Reference coordinate	CW Limit	Origin	Opposite end face	CCW Limit
KG07-W070A	Return to origin	9.3	0	2.1	9.3
KG07-W096A	Return to origin	7.3	0	1.6	7.3
KG07-W122A	Return to origin	5.3	0	1.3	5.3

* Return to origin means that is performed return to origin type 4 using DS102/DS112 controller.
 * The coordinate value should be on the design. Dimension error may occur about plus or minus 0.5 deg.

Method for return to origin

Suruga's motorized stages are different from the specification depending on the models. Therefore return to origin method other than recommendation may not be work correctly. Set to the way of recommendation return origin when using our controller.

■ G07/KA07 recommended return to origin Return to origin sequence P.1-281~

- Type 3: Detect in the direction of CCW and perform detected process for CCW edge(a point) of ORG signal.
- Type 4: Detect in the direction of CW and perform detected process for CW edge of ORG signal.
- Type 9: After finished Type3, perform detected process for CCW edge of TIMING signal.
- Type 10: After finished Type4, perform detected process for CW edge of TIMING signal.

[Type3] Detect in the direction of CCW and perform detected process for CCW edge (a point) of ORG signal.

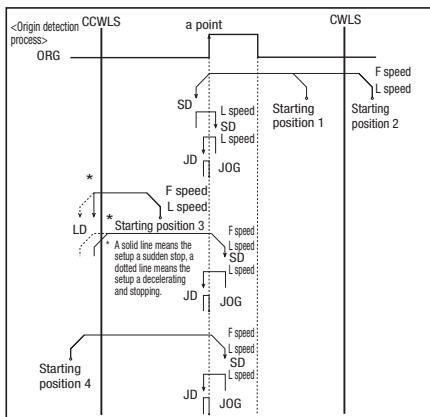

[Type4] Detect in the direction of CW and perform detected process for CW edge of ORG signal.

